

User Manual

K-BUS KNX GPS Weather Station_V1.2

CSWS-04/00.1.00



KNX/EIB Home and Building Control System

Attentions

1. Please keep devices away from strong magnetic field, high temperature, wet environment;

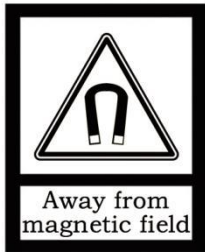

2. Do not fall the device to the ground or make them get hard impact;



3. Do not use wet cloth or volatile reagent to wipe the device;



4. Do not disassemble the devices.

Contents

Chapter 1 Summary	1
Chapter 2 Technical data	3
Chapter 3 Dimension and structural diagram	3
3.1 Dimension diagram	4
3.2 Structural diagram	5
3.3 Installation instructions	6
Chapter 4 Parameter setting description in the ETS	13
4.1 Parameter window "General settings"	13
4.2 Parameter window "GPS settings"	16
4.3 Parameter window "Location"	19
4.4 Parameter window "Rain"	23
4.5 Parameter window "Night"	26
4.6 Parameter window "Temperature"	29
4.6.1 Parameter window "Temperature threshold value 1/2/3/4"	32
4.7 Parameter window "Wind"	38
4.7.1 Parameter window "Wind threshold value 1/2/3"	40
4.8 Parameter window "Brightness"	42
4.8.1 Parameter window "Brightness threshold value 1/2/3"	44
4.9 Parameter window "Dawn"	46
4.9.1 Parameter window "Dawn of the threshold value 1/2/3"	47
4.10 Parameter window "Shading"	49
4.10.1 Parameter window "Facade 1/.../8 settings"	55
4.10.1.1 Using shadow edge tracking and slat tracking	61
4.10.1.2 Orientation and inclination of the Facade	63
4.10.1.3 Slat type and determination of width and spacing	65
4.10.1.4 Slat position for horizontal slats	66
4.10.1.5 Slat position for vertical slats	68

4.10.2 Parameter window “Facade 1/.../8 Actions”	70
4.11 Parameter window “Calendar time switch”	80
4.11.1 Parameter window “Calendar clock period 1/2/3”	81
4.12 Parameter window “Weekly time switch”	84
4.12.1 Parameter window “Weekly clock Monday/.../Sunday”	85
4.12.1.1 Use of the weekly clock	89
4.13 Parameter window “Logic”	90
4.13.1 Parameter window “AND/OR logic 1/.../6”	93
Chapter 5 Description of communication object	99
5.1 Communication object of “General settings”	99
5.2 Communication object of “GPS settings”	100
5.3 Communication object of “Location”	101
5.4 Communication object of “Rain”	102
5.5 Communication object of “Night”	103
5.6 Communication object of “Temperature”	104
5.7 Communication object of “Wind”	107
5.8 Communication object of “Brightness”	109
5.9 Communication object of “Dawn”	111
5.10 Communication object of “Shading”	112
5.11 Communication object of “Calendar time switch”	114
5.12 Communication object of “Weekly time switch”	115
5.13 Communication object of “Logic”	116

Chapter 1 Summary

The KNX GPS Weather Station for the KNX building bus system measures temperature, wind speed, brightness and recognizes precipitation.

All values can be used for the control of limit dependent switching outputs. States can be linked via AND logic gates and OR logic gates.

A GPS receiver provides the time and location for calculating the position of the sun (azimuth, elevation). The integrated shading control system allows the sun shading of eight Facades to be controlled.

Functions:

- Wind measurement with cup anemometer
- Precipitation detection: The sensor surface is heated, so that only drops and flakes are recognized as precipitation, but not mist or dew. When the rain or snow stops, the sensor is soon dry again and the precipitation warning ends
- Temperature measurement
- Switching outputs for all measured values. Threshold values can be adjusted per parameter or via communication objects
- 6 AND and 6 OR logic gates, each with 4 inputs. All switching events as well as 16 logic inputs (in the form of communications objects) can be used as inputs for the logic gates. The output of each gate can be configured optionally as 1-bit or 2 x 8-bit
- Brightness measurement (current illuminance). Measurement with 3 separate sensors, output of the current highest value (one maximum value). Separate threshold values for night
- GPS receiver, outputting the current time and location coordinates. The KNX GPS Weather Station also computes the position of the sun (azimuth and elevation)
- Shade control for up to 8 Facades with slat tracking and shadow edge tracking
- Weekly and calendar time switch: The weather station receives the time and date from the integrated GPS receiver. The weekly time switch switches up to 4 different periods per day. With

the calendar time switch up to 3 additional time periods can be defined, in which up to 2 On/Off switches take place. The switching outputs can be used as communications objects. The switch times are set via parameters

Chapter 2 Technical data

General	Installation	Assembly on-wall
	Degree of protection	IP44
	Dimensions(W x H x D)	113*101*225mm
	Total weight	≈260g
	Ambient temperature	-25...+50°C
	Storage temperature	-30...+70°C
KNX bus	Bus voltage	21-30V DC, via the KNX bus
	Bus current	≤18mA/24V DC, ≤15mA/30V DC
	Bus consumption	≤450mW
	Duration after bus voltage restoration until data is received	≈5s
	Medium	TP1-256
	Configuration mode	S-Mode
Auxiliary supply	Voltage	24~30 V DC
	Current	≤65mA/24V DC
	consumption	≤1.6 W
Connection KNX plug-in terminal	Conductor diameter	Ø0.8mms
	Stripping length	5mm
Sensors	Measurement range temperature	-25...+50°C
	Measurement range wind [at]	2...30m/s[25°C]
	Measurement range brightness	0 Lux...150000 Lux

Application	Maximum of communication objects	Maximum number of group addresses	Maximum number of associations
KNX GPS Weather Station/1.0	254	254	254

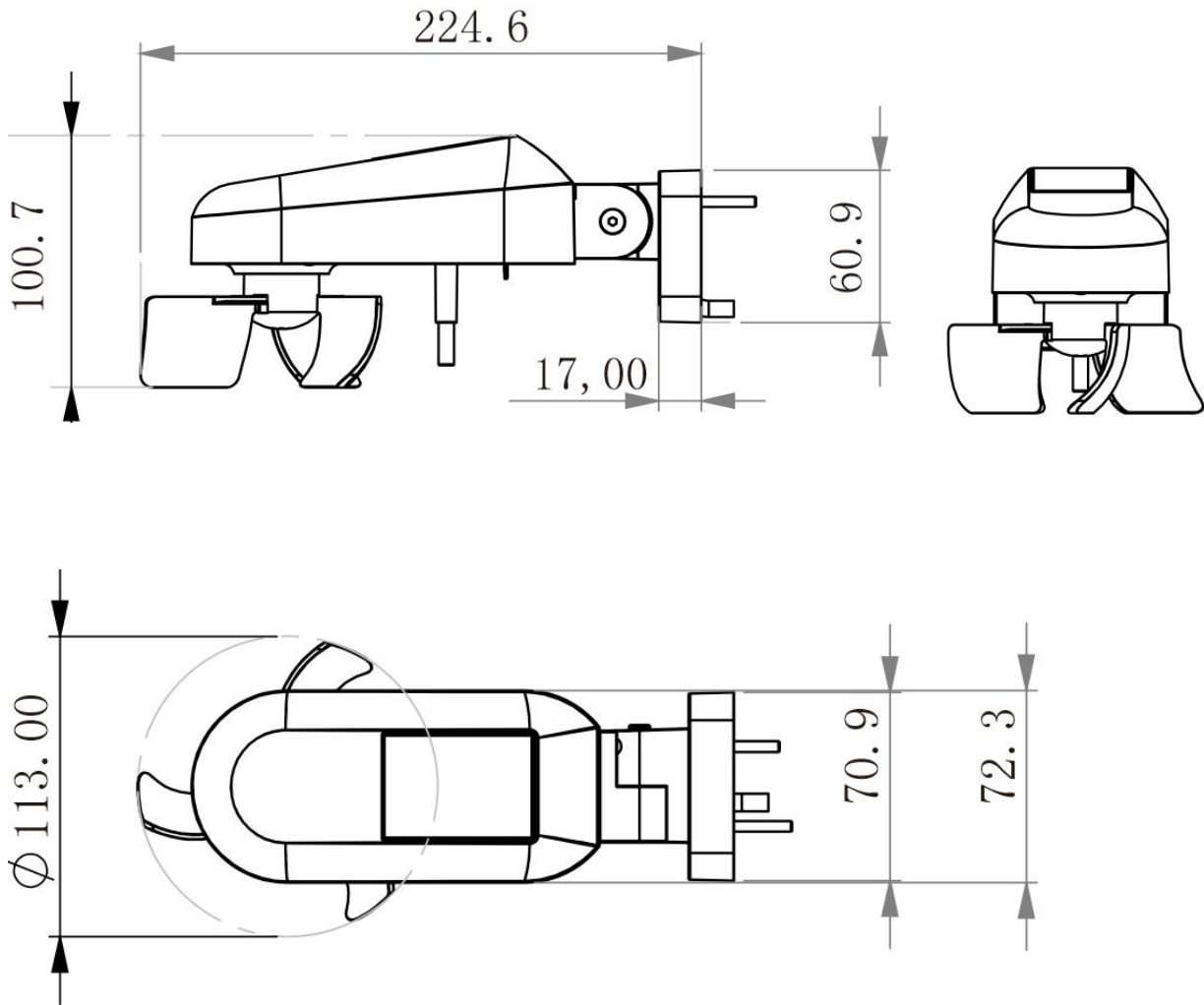
Chapter 3 Dimension and structural diagram**3.1 Dimension diagram**

3.2 Structural diagram

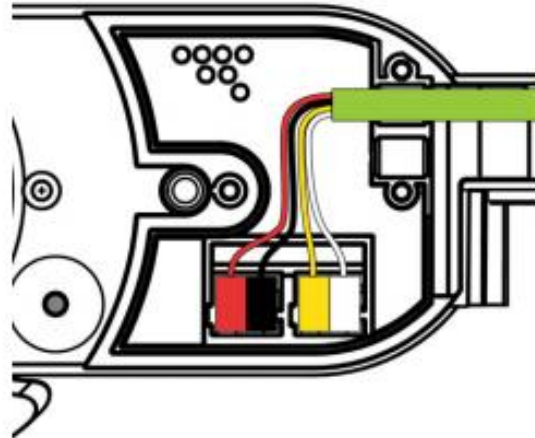

KNX	Auxiliary voltage
+ Red	+ Yellow
- Black	- White

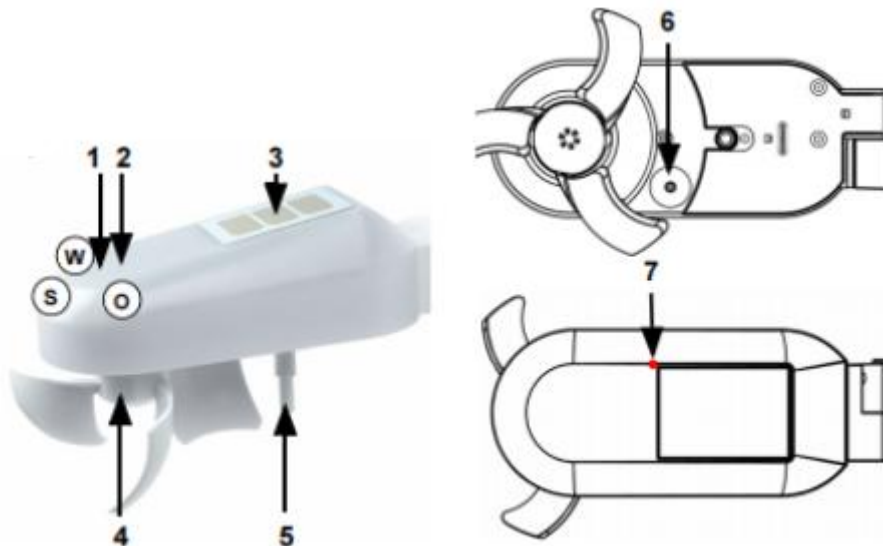

1. Brightness sensors. When facing south, the following applies.

Sensor O = East ; Sensor S = South ; Sensor W = West

2. GPS receiver 3. Rain sensor 4. Wind measuring element 5. Temperature sensor

6. Programming button 7. Programming LED (under the semi-transparent lid)

3.3 Installation instructions

**WARNING!****Danger due to overheating of the unit!**

If the current consumption of the auxiliary voltage exceeds 4 A, the device may overheat in the event of a short circuit.

- If you use a power supply unit with an output current of more than 4 A, fuse the supply voltage line of the auxiliary voltage with a maximum of 4 A.
- Place out of reach of persons.
- Select an installation position on the building where the sensors can measure wind, rain and sunshine without hindrance.
- Do not install below construction parts from which water can still drip onto the rain sensor even after it has stopped raining or snowing.
- Sources of interference (e.g. dark surfaces) below the installation location can distort the temperature measurement and should be avoided.
- Do not place near magnetic fields, transmitters and interference fields from electrical consumers (e.g. fluorescent lamps, neon signs, switching power supplies, etc.) as this may interfere with GPS reception)

Fig.1



Fig.2+3

Leave a distance of at least 60 cm be low, to the sides and to the front from other elements (building structure, construction parts, etc.). Mount horizontally in the transverse and longitudinal directions.

Fig. 2

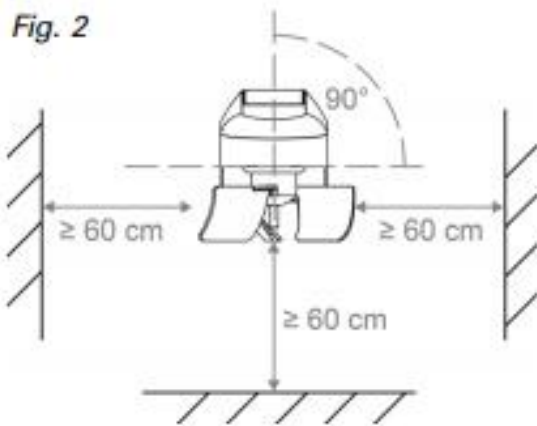

Fig. 3

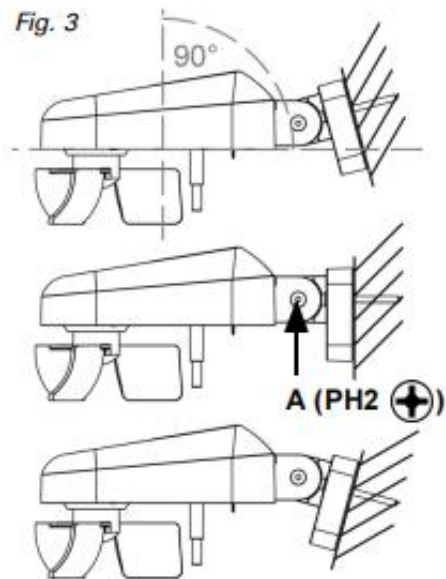

Fig.4 Measurement direction of the brightness sensor

Northern hemisphere: align south; Southern hemisphere: align north.

Sensor O = East; S = South; W = West, measurement directed outwards in each case.

Fig. 4

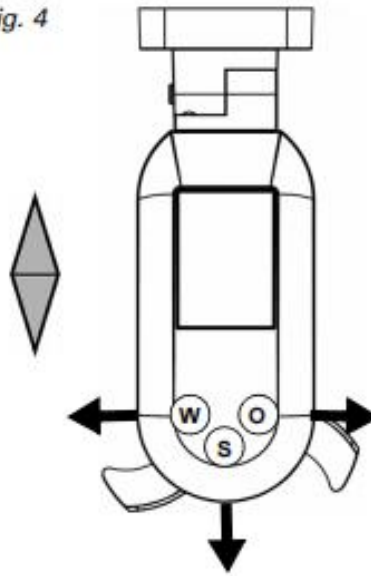

Fig. 5 Position of the sensors

1. Brightness sensors. When facing south, the following applies

Sensor O = East

Sensor S = South

Sensor W = West

2. GPS receiver

3. Rain sensor

4. Wind measuring element

5. Temperature sensor

Fig. 5

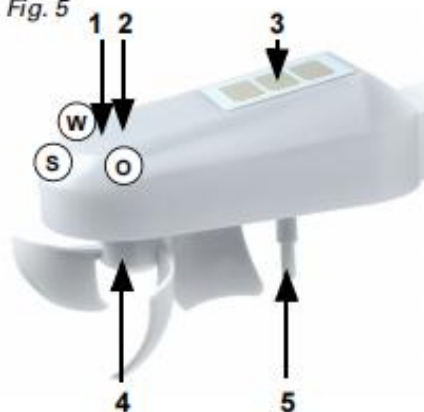

Attach mount

Release the screws of the mount (Fig. 3 A) and the cover (Fig. 6, red). Lead the KNX-TP cable (marked green) either through the mount (Fig. 7 + 8a) or later directly into the weather station (Fig. 6 + 8b).

Fig. 7: Attach the mount to the wall with two screws (Use holes with 30 mm spacing or break out the two holes with 55 mm spacing). Use fastening material (dowels, screws) suitable for the base. Slide the unit onto the mount from the front. Tighten the screw (Fig. 3 A) with the lock nut so that the weather station is horizontal.

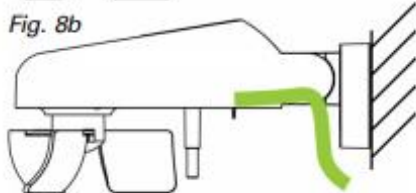
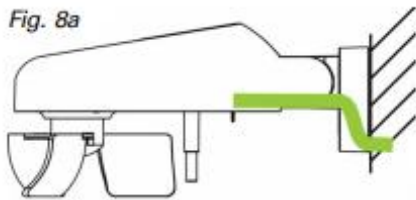
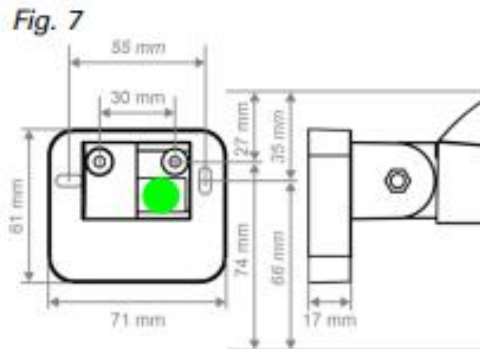
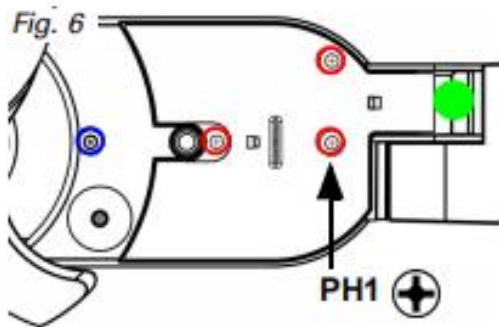

Connecting the device

If the rain sensor is used, the auxiliary voltage must be connected. Without auxiliary voltage, reliable rain and snow detection can not be guaranteed. Insert the KNX-TP cable through the outer cable guide and connect the bus and auxiliary voltage (Fig. 9).

KNX	Auxiliary voltage
+ Red	+ Yellow
- Black	- White

Attach the cover for the connection cable again with the 3 screws (Fig. 6 red), this provides strain relief for the connection cable.

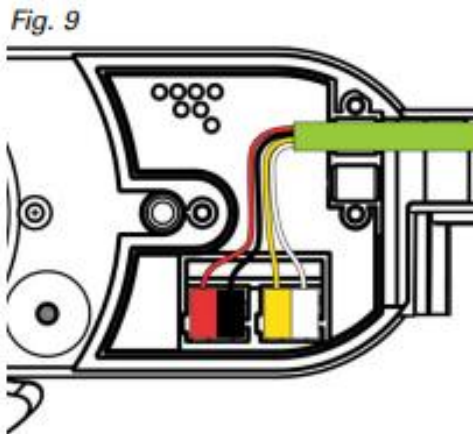

Second cable bushing

To use the second, internal cable bushing, the cover must be broken out at the corresponding point (Fig. 10). This allows a second KNX cable to be looped through (Fig. 11).

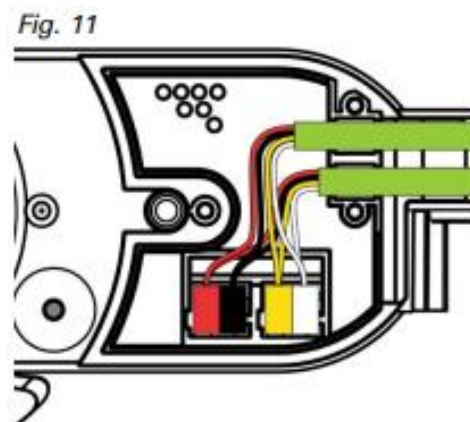
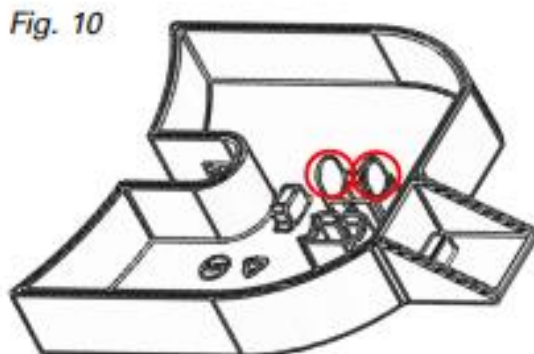

Fig. 12 Remove sticker

Remove the instruction stickers after installation.

Pole installation: The Fix P pole mount is required for pole mounting.

Installation with mounting arms: When installing the weather station with a mounting arm, use the cover on the back of the mount to prevent rain from entering the mount.

Fig. 12

**Drainage openings**

If necessary, the two drainage openings can be broken out (Fig. 13, red). To do this, the screw (Fig. 6, blue) of the housing cover must be loosened.

Fig. 13

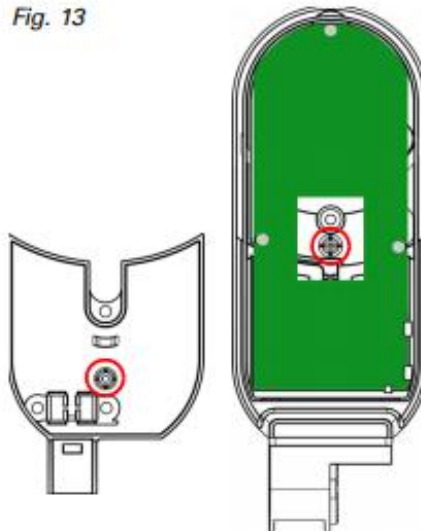
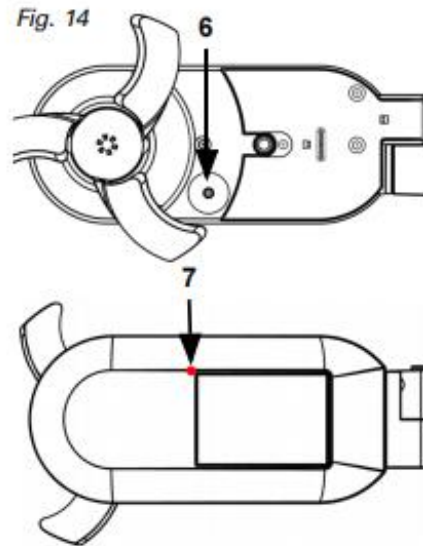

Fig.14 Addressing the equipment

6. Programming button

7. Programming LED (under the semi-transparent lid)



Maintenance



WARNING!

Risk of injury caused by components moved automatically! Always isolate the system from the mains for servicing and cleaning. The device must regularly be checked for dirt twice a year and cleaned if necessary.



ATTENTION

The device can be damaged if water penetrates the housing. Do not clean with high pressure cleaners or steam jets.

Chapter 4 Parameter setting description in the ETS

4.1 Parameter window “General settings”

Transmission delays after
power-up and programming for:

Measured values	5 sec
Threshold values and switching outputs	5 sec
Logic outputs	5 sec
Maximum telegram quota	5 Telegrams per second
send object auxiliary voltage status	not

The Windancer KNX-GPS weather station has a GPS receiver that provides the date and time, among other things. Since there should only be one message for date/time in a KNX-system (e.g. when using several GPS weather stations), the procedure for dealing with the time signal of the weather station is set here. If the date and time are set by the GPS signal and not sent, then they are only used internally, e.g. to calculate the position of the sun. By sending to the bus (periodically or on request), the date and time of the weather station can also be used by other bus participants. Alternatively, the date and time can be set by communication objects (i.e. from the bus). This setting is useful if another bus participant is to specify the time signal uniformly.

Fig.4.1 Parameter window “General settings”

Transmission delays after power-up and programming for:

Parameter “Measured values”

Parameter “Threshold value and switching outputs”

Parameter “Logic outputs”

First set the send delays after power up and programming here.

These delays should be coordinated with the entire KNX system, i.e. in a KNX system with many participants, care should be taken that the bus is not overloaded after a KNX bus reset. The messages of the individual participants should be sent offset.

Options:

5sec

10s

...

1.5h

2h

Parameter "Maximum telegram rate"

The bus load is limited with the aid of the maximum message rate. Many messages per second put a strain on the bus, but ensure faster data transmission.

Options:

1 Telegram per second

2 Telegram per second

...

20 Telegram per second

Parameter "Send object auxiliary voltage status"

The auxiliary voltage status object indicates whether the auxiliary voltage is connected to the weather station. If the rain sensor is used, then the auxiliary voltage must be connected.

This parameter is used to set the transmission behavior of the send object auxiliary voltage status.

Options:

not

on change

on change and periodically

—Parameter “Send cycle(only if date and time are transmitted "periodically)”

This parameter is visible when previous parameter is selected “on change and periodically”. When sending periodically, the object auxiliary voltage status is sent on the bus in a fixed cycle that can be set here.

Options:

5sec

10s

...

1.5h

2h

4.2 Parameter window "GPS settings"

The KNX GPS Weather Station has a GPS receiver that provides the date and time, among other things. Since there should only be one message for date/time in a KNX system (e.g. when using several GPS weather stations), the procedure for dealing with the time signal of the weather station is set here.

If the date and time are set by the GPS signal and not sent, then they are only used internally, e.g. to calculate the position of the sun.

By sending to the bus (periodically or on request), the date and time of the weather station can also be used by other bus participants.

The date and time can be set by communication objects (i.e. from the bus).

Date and time will be set by	GPS signal and transmitted on request and periodically
Send cycle	1 min
If there is no reception, GPS malfunction will be recognised after last reception/ reset	30 min
After auxiliary voltage is restored it can take up to 10 minutes till GPS OK.	
Object GPS malfunction transmits (1 = Malfunction 0 = no Malfunction)	on change and periodically
Send cycle	30 sec

Fig.4.2 Parameter window "GPS settings"

Parameter "Date and time will be set by"

Specify whether the time and date are to be set by the GPS signal or objects.

If time and date are set by the GPS-Signal, the data is available as soon as a valid GPS signal is received.

If time and date are set by the GPS-Signal, the data is available as soon as a valid GPS signal is received.

Options:

GPS signal and not transmitted

GPS signal and sent transmitted periodically

GPS signal and transmitted on request

GPS signal and transmitted on request and periodically

Communication objects and not sent

—Parameter **“Send cycle”**

This parameter is visible when previous parameter is selected “GPS signal and sent transmitted periodically” and “GPS signal and transmitted on request and periodically”.

When sending periodically, the date and time are sent on the bus in a fixed cycle that can be set here.

Options:

5sec

10s

...

1.5h

2h

Parameter **“If there is no reception, GPS malfunction will be recognised after last reception/reset”**

After the bus voltage is applied or restored, it can take up to 10 minutes until the GPS signal is received, sometimes even longer at locations with poor GPS reception. Therefore, a longer duration should be chosen in such cases.

Options:

20min

30min

...

1.5h

2h

After auxiliary voltage is restored it can take up to 10 minutes till GPS OK.

Parameter "Object GPS malfunction transmits(1=Malfunction | 0=no Malfunction)"

The information of the GPS fault can be used by other bus participants for monitoring. The transmission behaviour can be set here to match this.

Options:

not

on change

on change to 1

on change to 0

on change and periodically

on change to 1 and periodically

on change to 0 and periodically

—Parameter "Send cycle"

This parameter is visible when previous parameter is selected "on change and periodically", "on change to 1 and periodically" and "on change to 0 and periodically".

When sending periodically, the GPS fault is sent on the bus in a fixed cycle that can be set here.

Options:

5sec

10s

...

1.5h

2h

4.3 Parameter window "Location"

The KNX GPS Weather Station has a GPS receiver that provides the geo-position, among other things. The location is required in order to be able to calculate the position of the sun with the help of the date and time. During the initial start-up, the input coordinates are used for as long as no GPS reception exists.

In order to be able to display the correct time, the location must also be known. Only in this way can the weather station automatically take into account the UTC offset (difference from world time) and the summer/winter time change-over.

ATTENTION:

For the UTC offset and

the summer/winter time change-over
the location must be set

Country	Germany
Location	Aachen
Time zone definition	<input checked="" type="radio"/> standard <input type="radio"/> specific
Summer/winter time change-over on the	ST: Sun. after 25 March WT: Sun. after 25 Oct.
Rule for summer/winter time switching and UTC offset	03257:0200+0100/10257:0200UTC+0100
Location coordinates	cyclically send
Send cycle	1 min

Fig.4.3 Parameter window "Location"

ATTENTION: For the UTC offset and the summer/winter time change-over the location must be set.

Parameter "Country"

Parameter "Location"

The coordinates of various towns are saved in the weather station.

Options: **Other country/Belgium/.../UK**

Options: [**Dependent on the "Country" setting**]

Parameters as follow are visible when "country" is selected "other country".

—Parameter **"Degree of longitude [west -180...+180 east]"**

—Parameter **"Minute of longitude [west -59...+59 east]"**

—Parameter **"Degree of latitude [south -90...+90 north]"**

—Parameter **"Minute of latitude [south -59...+59 north]"**

—Parameter **"Rule for summer/winter time switching and UTC offset"**

This parameter is used to set the latitude and longitude position of other countries.

For example, enter (40° 43' northern latitude, 74° 0' western longitude) for New York, USA.

Parameter **"Time zone definition"**

The summer/winter time change-over takes place automatically when "Time zone definition standard" is selected. If "Time zone definition specific" is selected, the rule for the change-over can be adjusted manually.

Options:

Standard

Specific

—Parameter **"Summer/winter time change-over on the"**

Options: ST: Sun. after 25 March WT: Sun. after 25 Oct.

—Parameter **"Rule for summer/winter time switching and UTC offset"**

Options:0 [can be specified manually here][Change only possible with "Specific time zone definition"]

Example string: 03257:0200+0100/10257:0200UTC+0100

03257 Switchover date winter to summer [03 = month, 25 = day, 7 = weekday (7 ≙ Sunday)]

0200 Switchover time winter to summer [02 = hours, 00 = minutes] (standard time = winter time)

+0100 Changeover difference [01 = hours, 00 = minutes] (+0000 = no changeover)

10257 Switchover date summer to winter [10 = month, 25 = day, 7 = weekday (7 ≙ Sunday)]

0200 Switchover time summer to winter [02 = hours, 00 = minutes] (standard time = winter time)

UTC+0100 Time zone [01 = hours, 00 = minutes] (-1200 ... +1400)

Parameter "Location coordinates"

The location coordinates can be sent on the KNX bus if required. Sending on change or periodically is more useful for movable structures, such as mobile homes or ships.

Options:

not send

cyclically send

send in case of change

send in case of change and cyclically

—Parameter "Send cycle"

This parameter is visible when previous parameter is selected "cyclically send" and "send in case of change and cyclically".

When sending periodically, the position coordinates are sent on the bus in a fixed cycle that can be set here.

Options:

5sec

10s

...

1.5h

2h

—Parameter “on change of”

This parameter is visible when previous parameter is selected “send in case of change” and “send in case of change and cyclically”.

When sending on change, the location coordinates are sent on the bus as soon as they change by the longitude and latitude set here.

Options:

0.5°

1°

...

10°

4.4 Parameter window "Rain"

If the rain sensor is used, then the auxiliary voltage must be connected. The auxiliary voltage feeds the heating of the rain sensor. Only when the rain sensor is heated, the end of precipitation is detected promptly and false alarms caused by fog or dew are avoided.

Use rain sensor	<input type="radio"/> No <input checked="" type="radio"/> Yes
When it rains the switching output is	<input type="radio"/> 0 <input checked="" type="radio"/> 1
Delays can be set via objects (in seconds)	<input checked="" type="radio"/> No <input type="radio"/> Yes
Switch delay to rain	none ▼
Switching delay to no rain after it is dry	5 min ▼
Switching output sends	on change ▼
Use rain output 2 with fixed switching delays	<input type="radio"/> No <input checked="" type="radio"/> Yes
No delay on rain recognition 5 minutes delay after drying	

Fig.4.4 Parameter window ""

Parameter "Use rain sensor"

This parameter is used to set whether use rain sensor.

Options:

No

Yes

Parameters as follow are visible when "use rain sensor" is selected "yes".

Parameter "When it rains the switching output is"

The object value is defined for rain.

Options:

0

1

Parameter "Delay can be set via objects(in seconds)"

The delay times in seconds can be defined via objects.

Options:

No

Yes

—Parameter "Switch delay to rain"

—Parameter "Switch delay to no rain after it is dry"

These parameters are visible when previous parameter is selected "NO"

With longer switching delays, a short rain shower or a short dry phase are not reported.

Options: **none/5 sec/10s/.../1.5h/2h**

Options: **5 min/10s/.../1.5h/2h**

Parameter "Switching output sends"

Here you set when the switching output is to be sent to the bus.

Options:

on change

on change to 1

on change to 0

on change and periodically

on change to 1 and periodically

on change to 0 and periodically

—Parameter “Send cycle”

This parameter is visible when previous parameter is selected “on change and periodically”, “on change to 1 and periodically” and “on change to 0 and periodically”.

When sending periodically, the rain switching output is sent on the bus in a fixed cycle that can be set here.

Options:

5sec

10s

...

1.5h

2h

Parameter “Use rain output 2 with fixed switching delay”

The additional rain output is used when 2 rain outputs with different delays are needed.

If, for example, windows and awnings are to be controlled on a Facade, they can react differently to rain. For windows, the longer rain delay time would ensure that the motors do not run constantly in changeable weather. The awnings on the same Facade would react quickly with the help of the 2nd rain output.

Options:

No

Yes

4.5 Parameter window "Night"

Use night recognition	<input type="radio"/> No <input checked="" type="radio"/> Yes
Night will be recognised below 10 Lux.	
At night the switching output is	<input type="radio"/> 0 <input checked="" type="radio"/> 1
Delays can be set via objects (in seconds)	<input checked="" type="radio"/> No <input type="radio"/> Yes
Switching delay on night	5 sec ▼
Switching delay on day	5 sec ▼
Switching output sends	on change and periodically ▼
Send cycle	5 sec ▼

Fig.4.5 Parameter window ""

Parameter "Use night recognition"

This parameter is used to set whether use night recognition.

Options:

No

Yes

Parameters as follow are visible when "use night recognition" is selected "yes".

Night will be recognized below 10 Lux.

Parameter "At night the switching output is"

Here you can set whether a 1 or 0 is sent to the bus at night.

Options:

0

1

Parameter "Delays can be set via objects(in seconds)"

The delay times in seconds can be defined via objects.

Options:

No

Yes

—Parameter **"Switch delay on night"**

—Parameter **"Switch delay on day"**

These parameters are visible when previous parameter is selected "NO".

Switching delays can be used to compensate for minor brightness fluctuations, e.g. darkening due to clouds at twilight.

Options: **none/5 sec/10s/.../1.5h/2h**

Options: **none/5 sec/10s/.../1.5h/2h**

Parameter "Switching output sends "

Here you set when the switching output is to be sent to the bus.

Options:

on change

on change to 1

on change to 0

on change and periodically

on change to 1 and periodically

on change to 0 and periodically

—Parameter **"Send cycle"**

This parameter is visible when previous parameter is selected "on change and periodically", "on change to 1 and periodically" and "on change to 0 and periodically".

When sending periodically, the night switching output is sent on the bus in a fixed cycle that can be set here.

Options:

5sec

10s

...

1.5h

2h

4.6 Parameter window "Temperature"

Offset in 0.1°C	<input type="text" value="1"/>
Measured value	<input type="text" value="send in case of change and cyclically"/>
on change of	<input type="text" value="10%"/>
Send cycle	<input type="text" value="5 sec"/>
Use minimum and maximum values	<input type="radio"/> No <input checked="" type="radio"/> Yes
Values are not maintained after reset.	
Use object "Temperature sensor malfunction"	<input type="radio"/> No <input checked="" type="radio"/> Yes
Use threshold value 1	<input type="radio"/> No <input checked="" type="radio"/> Yes
Use threshold value 2	<input type="radio"/> No <input checked="" type="radio"/> Yes
Use threshold value 3	<input type="radio"/> No <input checked="" type="radio"/> Yes
Use threshold value 4	<input type="radio"/> No <input checked="" type="radio"/> Yes

Fig.4.6 Parameter window ""

Parameter "Offset in 0.1°C"

The output temperature value can be corrected here by an offset value if required. In this way, deviations caused by sources of interference can be compensated for, e.g. dark surfaces that heat up.

Options: **-50...50**

Parameter "Measured value"

The temperature value can be sent to the bus and further processed there by other participants.

Options:

not send

cyclically send

send in case of change

send in case of change and cyclically

—Parameter “Send cycle”

This parameter is visible when previous parameter is selected “cyclically send” and “send in case of change and cyclically”.

When sending periodically, the temperature value is sent on the bus in a fixed cycle that can be set here.

Options:

5sec

10s

...

1.5h

2h

—Parameter “on change of”

This parameter is visible when previous parameter is selected “send in case of change” and “send in case of change and cyclically”.

When sending on change, the temperature value is sent on the bus as soon as it changes by the percentage set here.

Options:

2%

5%

...

25%

50%

Parameter “Use minimum and maximum values”

The highest (max.) and the lowest (min.) temperature value since programming or a reset can be sent to the bus. The two values can be reset via object no. 18 "Temperature measured value reset min./max."

Options:

No

Yes

Parameter "Use object "Temperature sensor malfunction""

The "Temperature sensor fault" object is used to monitor the function of the temperature sensor. A 1 is sent in case of a fault, otherwise a 0.

Options:

No

Yes

Parameter "Use threshold value 1/2/3/4"

This parameter sets whether use temperature threshold value 1/2/3/4.

Options:

No

Yes

4.6.1 Parameter window “Temperature threshold value 1/2/3/4”

The temperature threshold values are used to carry out certain actions when a temperature value is exceeded or not reached.

Threshold value:

Threshold value setpoint per Parameter Communication objects

Threshold value in 0.1°C

Switching distance (hysteresis) of the threshold value in %

Switching output:

Output is at (TV = threshold value) (SD = Switching distance)

Delays can be set via objects (in seconds) No Yes

Switching delay from 0 to 1

Switching delay from 1 to 0

Switching output sends

Send cycle

Blocking:

Use block of the switching output No Yes

Evaluation of the blocking object if value 1: block | if value 0: release
 if value 0: block | if value 1: release

Blocking object value before 1. communication 0 1

Behaviour of the switching output

With blocking

on release: (with 2 seconds release delay)

Fig.4.6.1 Parameter window “Temperature threshold value 1/2/3/4”

Threshold value:

Parameter "Threshold value setpoint per"

Here it is selected whether the threshold value is to be specified per parameter or via a communication object.

Options:

Parameter

Communication object

—Parameter "Threshold value in 0.1°C"

The parameter is visible when previous parameter is selected "parameter" .

When the threshold value per parameter is specified, then the value is set.

Options: **-300...800**

Parameter "Switching distance (hysteresis) of the threshold value in %"

This parameter is used to set the switching distance of the threshold value in %.

The switching distance prevents the switching output of the threshold value from changing too often in the event of temperature fluctuations. When the temperature drops, the switching output does not react until the switching distance falls below the threshold value (points 1 and 2 in the next parameter). When the temperature rises, the switching output only reacts when the switching distance falls below the threshold value (points 3 and 4 in the next parameter).

Options: **0...50**

These parameter is visible when "Threshold value setpoint per" is selected "Communication object" .

—Parameter "The value last communicated shall be retained"

Here it is set in which cases threshold values received by a communication object should be retained.

Please note that the setting "After power restoration and programming" should not be used for the initial start-up, as the factory settings are always used until the first Communication, the factory settings must always be used.

Options:

not

after power supply restoration

after power supply restoration and programming

—Parameter **"Start threshold value in 0.1°C valid until 1.communication"**

If the threshold value is set by a communication object, during the initial commissioning a threshold value must be specified which is valid until the 1st communication of a new threshold value. With weather stations that have already been taken into service, the last threshold value communicated is used.

From the 1st communication, the threshold value corresponds to the value of the communication object and is not multiplied by the factor 0.1.

Once a threshold value is set via parameter or communication object, the last set threshold value remains until a new threshold value is transmitted by a communication object.

The last threshold values set by communications objects are saved in the device, so that they are retained during a power outage and are available once again when power is restored.

Options: **-300...800**

—Parameter **"Type of threshold value change"**

The type of threshold value change is set here.

Options:

Absolute value

Increment/decrement

—Parameter **"Step size"**

This parameters are visible when previous parameter is selected "Increment/decrement".

The step size is selected here.

Switching output:

Parameter "Output is at (TV-threshold value)(SD=Switching distance)"

Here it is set which value the output transmits if the threshold value is exceeded or undercut.

Options:

TV above = 1 | TV - SD below = 0

TV above = 0 | TV - SD below = 1

TV below = 1 | TV - SD above = 0

TV below = 0 | TV - SD above = 1

Parameter "Delays can be set via objects (in seconds)"

This parameter is used to set whether delays can be set via objects.

Options:

No

Yes

—Parameter "Switch delay from 0 to 1"

—Parameter "Switch delay from 1 to 0"

These parameters are visible when previous parameter is selected "NO".

Switching delays ignore short-term temperature fluctuations around the threshold value or threshold value and switching distance for the switching output.

Options: **none/5 sec/10s/.../1.5h/2h**

Options: **none/5 sec/10s/.../1.5h/2h**

Parameter "Switching output sends"

Here you set when the switching output is to be sent to the bus.

Options:

on change

on change to 1

on change to 0

on change and periodically

on change to 1 and periodically

on change to 0 and periodically

—Parameter “Send cycle”

This parameter is visible when previous parameter is selected “on change and periodically”, “on change to 1 and periodically” and “on change to 0 and periodically”.

When sending periodically, the temperature threshold value switching output is sent on the bus in a fixed cycle that can be set here.

Options:

5sec

10s

...

1.5h

2h

Blocking:

Parameter “Use block of the switching output”

With the help of the “Blocking” input object, the switching output can be blocked, e.g. by a manual command (push button).

Options:

No

Yes

Parameters as follow are visible when “Use block of the switching output” is selected “yes”.

Parameter “Evaluation of the blocking object”

This parameter is used to set what a 1 or 0 at the block entry means.

Options:

If value 1:block | if value 0:release

If value 0:block | if value 1:release

Parameter "Blocking object value before 1. communication"

An object value up to the 1st communication is specified here.

Options:

0

1

Parameter "With blocking"

Parameter "on release:(with 2 seconds release delay)---Status object/s send/s"

The behaviour of the switching output during locking can be set.

Options: **do not send telegram/Send 0/Send 1**

Options: dependent on the value of the parameter "Switching output sends"

4.7 Parameter window "Wind"

Measured value	send in case of change and cyclically
on change of	10%
Send cycle	5 sec
Use maximum value	<input type="radio"/> No <input checked="" type="radio"/> Yes
Value is not maintained after reset	
Use threshold value 1	<input type="radio"/> No <input checked="" type="radio"/> Yes
Use threshold value 2	<input type="radio"/> No <input checked="" type="radio"/> Yes
Use threshold value 3	<input type="radio"/> No <input checked="" type="radio"/> Yes

Fig.4.7 Parameter window "Wind"

Parameter "Measured value"

The wind measurement value can be sent to the bus and further processed there by other participants.

Options:

not send

cyclically send

send in case of change

send in case of change and cyclically

—Parameter "Send cycle"

This parameter is visible when previous parameter is selected "cyclically send" and "send in case of change and cyclically".

When sending periodically, the wind measurement value is sent on the bus in a fixed cycle that can be set here.

Options:

5sec

10s

...

1.5h

2h

—Parameter “on change of”

This parameter is visible when previous parameter is selected “send in case of change” and “send in case of change and cyclically”.

When sending on change, the wind measurement value is sent on the bus as soon as it changes by the percentage set here.

Options:

2%

5%

...

25%

50%

Parameter “Use maximum values”

The highest wind measurement value since programming or a reset can be sent to the bus. This value can be reset via obj.47 “Wind measurement value reset max”.

Options:

No

Yes

Parameter “Use threshold value 1/2/3”

This parameter sets whether use wind threshold value 1/2/3/4.

Options: **No /Yes**

4.7.1 Parameter window “Wind threshold value 1/2/3”

The wind threshold values are used to carry out certain actions when the wind speed exceeds or falls below a certain value, e.g. protection functions for shades or windows.

Threshold value:

Threshold value setpoint per Parameter Communication objects

Threshold value in 0.1 m/s

Switching distance (hysteresis) of the threshold value in %

Switching output:

Output is at (TV = threshold value) (SD = Switching distance)

Delays can be set via objects (in seconds) No Yes

Switching delay from 0 to 1

Switching delay from 1 to 0

Switching output sends

Send cycle

Blocking:

Use block of the switching output No Yes

Evaluation of the blocking object if value 1: block | if value 0: release if value 0: block | if value 1: release

Blocking object value before 1. communication 0 1

Behaviour of the switching output

With blocking

on release: (with 2 seconds release delay)

Fig.4.7.1 Parameter window “Wind threshold value 1/2/3/4”

Parameter "Threshold value in 0.1m/s"

Each threshold value can be set individually.

Options:**1...350**

Other parameter settings are similar to those of the temperature threshold values, see section 4.6.1 for detailed operations.

4.8 Parameter window "Brightness"

If the shade automation is to be used, a threshold value must be active!

The KNX GPS Weather Station has three brightness sensors and uses the maximum value of these with 4 brightness threshold values.

Measured value	send in case of change and cyclically
on change of	10%
Send cycle	5 sec
Use threshold value 1	<input type="radio"/> No <input checked="" type="radio"/> Yes
Use threshold value 2	<input type="radio"/> No <input checked="" type="radio"/> Yes
Use threshold value 3	<input type="radio"/> No <input checked="" type="radio"/> Yes
Use threshold value 4	<input type="radio"/> No <input checked="" type="radio"/> Yes

Fig.4.8 Parameter window "Brightness"

Parameter "Measured value"

The weather station detects the current brightness. This value can be sent to the bus and further processed there by other participants.

The highest value currently measured by the three internal sensors is used as the brightness value.

Options:

not send

cyclically send

send in case of change

send in case of change and cyclically

—Parameter “Send cycle”

This parameter is visible when previous parameter is selected “cyclically send” and “send in case of change and cyclically”.

When sending periodically, the brightness measurement value is sent on the bus in a fixed cycle that can be set here.

Options:

5sec

10s

...

1.5h

2h

—Parameter “on change of”

This parameter is visible when previous parameter is selected “send in case of change” and “send in case of change and cyclically”.

When sending on change, the brightness measurement value sent on the bus as soon as it changes by the percentage set here.

Options:

2%

5%

...

25%

50%

Parameter “Use threshold value 1/2/3/4”

This parameter sets whether use brightness threshold value 1/2/3/4.

Options: **No/Yes**

4.8.1 Parameter window “Brightness threshold value 1/2/3”

The brightness threshold value values are used to perform certain actions when the illuminance exceeds or falls below an illuminance in the kilo lux range.

Threshold value:

Threshold value setpoint per Parameter Communication objects

Threshold value in klux

Switching distance (hysteresis) of the threshold value in %

Switching output:

Output is at (TV = threshold value) (SD = Switching distance)

Delays can be set via objects (in seconds) No Yes

Switching delay from 0 to 1

Switching delay from 1 to 0

Switching output sends

Send cycle

Blocking:

Use block of the switching output No Yes

Evaluation of the blocking object if value 1: block | if value 0: release
 if value 0: block | if value 1: release

Blocking object value before 1. communication 0 1

Behaviour of the switching output

With blocking

on release: (with 2 seconds release delay)

Fig.4.8.1 Parameter window “Brightness threshold value 1/2/3”

Parameter "Threshold value / start threshold value in klux"

Each threshold value can be set individually.

Options: **1...150**

Other parameter settings are similar to those of the temperature threshold values, see section 4.6.1 for detailed operations.

4.9 Parameter window "Dawn"

Use threshold value 1	<input type="radio"/> No	<input checked="" type="radio"/> Yes
Use threshold value 2	<input type="radio"/> No	<input checked="" type="radio"/> Yes
Use threshold value 3	<input type="radio"/> No	<input checked="" type="radio"/> Yes

Fig.4.9 Parameter window "Dawn"

Parameter "Use threshold value 1/2/3"

This parameter sets whether use dawn threshold value 1/2/3/4.

Options:

No

Yes

4.9.1 Parameter window “Dawn of the threshold value 1/2/3”

The twilight threshold values are used to perform certain actions when the illuminance exceeds or falls below an illuminance in the lux range.

Threshold value:

Threshold value setpoint per Parameter Communication objects

Threshold value in lux

Switching distance (hysteresis) of the threshold value in %

Switching output:

Output is at (TV = threshold value) (SD = Switching distance)

Delays can be set via objects (in seconds) No Yes

Switching delay from 0 to 1

Switching delay from 1 to 0

Switching output sends

Send cycle

Blocking:

Use block of the switching output No Yes

Evaluation of the blocking object if value 1: block | if value 0: release
 if value 0: block | if value 1: release

Blocking object value before 1. communication 0 1

Behaviour of the switching output

With blocking

on release: (with 2 seconds release delay)

Fig.4.9.1 Parameter window “Dawn of the threshold value 1/2/3”

Parameter "Threshold value / start threshold value in lux"

Each threshold value can be set individually.

Options: **1...1000**

Other parameter settings are similar to those of the temperature threshold values, see section 4.6.1 for detailed operations.

4.10 Parameter window "Shading"

The control options for shadings (shadow edge tracking and slat tracking) are Facade-related functions.

Most buildings have 4 facades. In principle the sun protection of each facade should be controlled separately, as shown in Fig.1.

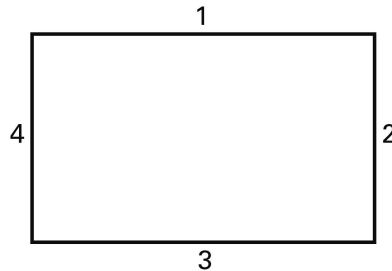

Fig.1

Even in buildings with a U-shaped layout only 4 facades have to be controlled differently, as several have the same alignment, as shown in Fig.2.

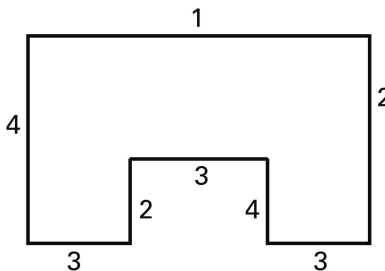

Fig.2

In buildings with an asymmetrical layout the facades with a non-right-angled orientation(2,4) must be controlled separately, as shown in Fig.3.

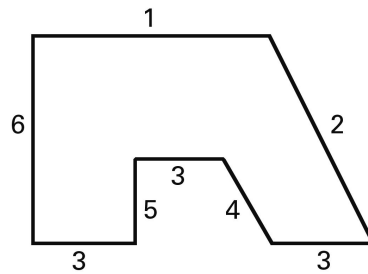

Fig.3

Curved/round fronts should be divided into several Facades (segments) to be controlled individually.

If a building has more than 8 Facades, another weather station should be used.

Depending on the location, it may make sense to use an additional wind speed sensor from 5 or 6 Facades. When there are several buildings, wind measurement should take place separately for each building, as, depending on the positions of the buildings in relation to one another, different wind speeds may occur.

Sun position	send in case of change and cyclically
on change of	1 Degree
Send cycle	1 min
Use façade 1	<input type="radio"/> No <input checked="" type="radio"/> Yes
Use façade 2	<input checked="" type="radio"/> No <input type="radio"/> Yes
Use façade 3	<input checked="" type="radio"/> No <input type="radio"/> Yes
Use façade 4	<input checked="" type="radio"/> No <input type="radio"/> Yes
Use façade 5	<input checked="" type="radio"/> No <input type="radio"/> Yes
Use façade 6	<input checked="" type="radio"/> No <input type="radio"/> Yes
Use façade 7	<input checked="" type="radio"/> No <input type="radio"/> Yes
Use façade 8	<input checked="" type="radio"/> No <input type="radio"/> Yes
Use heat protection temperature	<input type="radio"/> No <input checked="" type="radio"/> Yes
Heat protection temperature in °C	35
Switching distance (hysteresis) in °C	5
Heat protection is (HPTV = heat protection threshold value) (SD = Switching distance)	Active above = HPTV Inactive below HPTV - SD
Transmit "Façades heat protection status" object	on change to 1 and periodically
Send cycle	1 min

Fig.4.10 Parameter window "Shading"

Parameter "Sun position"

The KNX GPS Weather Station calculates the direction (azimuth) and altitude (elevation) of the sun from current time data and position. Sending the sun position is purely informative.

Options:

not send

cyclically send

send in case of change

send in case of change and cyclically

—Parameter **“Send cycle”**

This parameter is visible when previous parameter is selected “cyclically send” and “send in case of change and cyclically”.

When sending periodically, the sun position is sent on the bus in a fixed cycle that can be set here.

Options:

5sec

10s

...

1.5h

2h

—Parameter **“on change of” Degree**

This parameter is visible when previous parameter is selected “send in case of change” and “send in case of change and cyclically”.

If the position of the sun changes by the angle set here, the value is sent to the bus.

Options: **1...15**

Parameter **“Use facade 1/2/.../7/8”**

How many Facades are used depends on the project requirements.

Options:

No

Yes

Parameter "Use heat protection temperature"

Measures for summer heat protection can be initiated via the heat protection temperature or the object output "Heat protection status" (number 114), e.g. closing roller shutters.

Options:

No

Yes

Parameters as follow are visible when "Use heat protection temperature" is selected "yes".

Parameter "Heat protection temperature in °C"

This parameter sets the heat protection temperature.

Options: **15...50**

Parameter "Switching distance (hysteresis) in °C"**Parameter "Heat protection is (HPTV = heat protection threshold value) (SD = Switching distance)--**

Active above = HPTV | Inactive below HPTV - SD"

The switching distance value determines by how many °C the temperature must fall below the threshold value until the heat protection is inactive again.

Options: **5...20**

Parameter "Transmit "Facades heat protection status" object"

Sending only on change or even only on change in one direction (1 = active or 0 = inactive) reduces the load on the bus.

Options:

on change

on change to 1

on change to 0

on change and periodically

on change to 1 and periodically

on change to 0 and periodically

—Parameter “Send cycle”

This parameter is visible when previous parameter is selected “on change and periodically”, “on change to 1 and periodically” and “on change to 0 and periodically”.

When sending periodically, the object “Facade heat protection status” is sent on the bus fixed cycle that can be set here.

Options:

5sec

10s

...

1.5h

2h

4.10.1 Parameter window "Facade 1/.../8 settings"

Shade conditions:

The brightness condition is fulfilled if

The brightness is greater than the ▾

The brightness condition is not fulfilled if the brightness is less than the limit threshold - switching distance (hysteresis).

Switching distance (hysteresis) in % of the threshold value ▴ ▾

The sun position condition fulfilled if

Sun ▾

Shade settings:

Type of tracking ▾

Façade alignment (North=0°, East=90°, South=180°, West=270°) ▴ ▾ °

Inclination of the façade (0° = no inclination) ▴ ▾ °

Window height ▴ ▾ cm

Maximum penetration depth of the sun into the room ▴ ▾ cm

It is updated from a shadow movement of ▴ ▾ cm

Slat width ▴ ▾ mm

Slat distance ▴ ▾ mm

Minimum angle change to transmit the new slat position ▴ ▾ °

Slat angle for position command "0%" ▴ ▾ °

Slat angle for position command "100%" ▴ ▾ °

Fig.4.10.1 Parameter window "Facade 1/.../8 settings"

Shade conditions:**The brightness condition is fulfilled if**

Parameter "The brightness is greater than the"

The first condition for shading is that the brightness limit value is exceeded. The threshold value set up accordingly in advance is selected here. For explanations of the brightness threshold value, see chapter 4.8.1.

Options:

Brightness threshold value 1

Brightness threshold value 2

Brightness threshold value 3

Brightness threshold value 4

Parameter "Switching distance (hysteresis) in % of the threshold value"

The brightness threshold value is additionally provided with a switching distance, with the help of which smaller brightness fluctuations around the threshold value are filtered out.

Options: **0...50**

Parameter "Sun"

The sun position condition defines the position of the sun at which shading is to take place. Generally, the sun direction set here should correspond to the orientation of the Facade. In addition, the shadows cast by roof overhangs, neighbouring buildings or trees can be taken into account and these angled areas can also be excluded from shading. The aim is to shade only when the Facade is in the sun.

For the direction of the sun (azimuth), predefined angle ranges can be used or an own angle range can be specified numerically.

Options:

from the East (Azimuth 0°...180°)

from the South-east (Azimuth 45°...225°)

from the South (Azimuth 90°...270°)

from the south-west (Azimut 135°...315°)

from the West (Azimuth 180°...360°)

in the range

Parameter "Direction of the sun from"

Parameter "Direction of the sun up to"

Parameter "Height of the sun from"

Parameter "Height of the sun up to"

This parameter is visible when previous parameter is selected "in the range" .

For angle setting of the sun's range:

Options:

0...360°

0...360°

0...90°

0...90°

Direction setting example:

Top view: in the morning, for example, the building is fully shaded by surrounding trees.

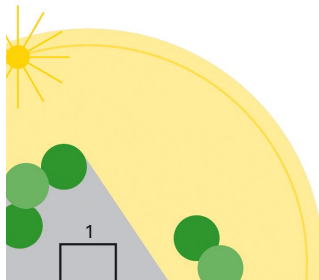

Top view: for facade 1, shading must only be active in the azimuth marked red, as the sun can then shine on to the building without obstruction.

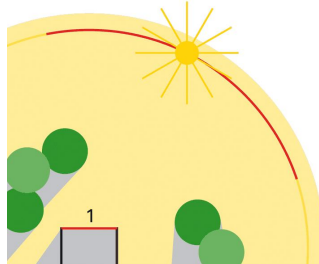

Height setting example:

Side view: when the sun's position is high, the facade is only shaded by the roof over hang. Shading is only necessary if the sun is low (in the figure approx. below 53°).

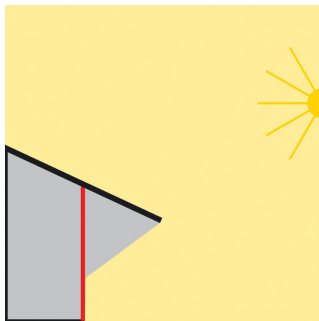

Parameter "Type of tracking"

The slat tracking is only suitable for slat blinds and, by tilting the slats, ensures that no direct sun but as much daylight as possible enters the room.

Options:

No tracking

Shadow edge tracking and slat tracking

Slat tracking

Shadow edge tracking and slat tracking

Parameter "Facade alignment (North=0°, East=90°, South=180°, West=270°)"

Parameter "Inclination of the facade(0° = no inclination)"

For the correct calculation of the shadow edge tracking, the compass direction and inclination of the Facade must be entered. For detailed operations see chapter 4.11.1.2.

Options:

0...360°

-90...90°

Parameter "Slat orientation"

This parameter is visible when parameter "Type of tracking" is selected "Slat tracking".

This parameter is used to set the slat orientation.

For detailed operations see chapter 4.11.1 and 4,4.11.1.5.

Options:

Horizontal

Vertical

Parameters as follow are visible when parameter "type of tracking" is selected "Slat tracking/Shadow edge tracking and slat tracking".

Parameter "Slat width"

Parameter "Slat distance"

This parameter is used to set the slat width and distance. For detailed operations see chapter 4.11.1.3.

Options: **1...1000mm**

Parameter "Minimum angle change to transmit the new slat position"

The fineness of the tracking is set by the minimum angle change.

Options: **1...90°**

Parameter "Slat angle for position command "0%""

Parameter "Slat angle for position command "100%""

The slat angles in the upper stop position (0%) and lower stop position (100%) differ depending on the type of blind. For detailed operations see chapter 4.11.1.2.

Options: **0...180°**

Parameters as follow are visible when parameter "type of tracking" is selected "Shadow edge tracking and slat tracking/Shadow edge tracking and slat tracking".

Parameter "Window height"

The distance from the floor to the top edge of the window (window height) is required for correct shadow edge tracking.

Options: **1...1000cm**

Parameter "Maximum penetration depth of the sun into the room"

The maximum penetration depth defines how far the sun may shine into the room as seen from the Facade/window area. This can prevent sensitive plants from being exposed to direct sunlight, for example.

Options: **10...250 cm**

Parameter "It is updated from a shadow movement of"

The fineness of the tracking is set by the movement in cm.

Options: **1...50cm**

4.10.1.1 Using shadow edge tracking and slat tracking

With shadow edge tracking the sunshade is not moved down fully; rather it is moved only so far that the sun can still shine a parameter distance (e.g. 50 cm) into the room.

The shadow edge tracking is only usable with a sunshade which is moved from the top downwards (e.g. shutters, textile shades or blinds with horizontal slats). This function is not usable with sunshades which are pulled in front of a window from one or both sides.

During slat tracking the horizontal slats of shutters are not fully closed but rather automatically adjusted according to the position of the sun so that it cannot shine directly into the room. Diffuse daylight can still enter the room through the slats and contribute to dazzle-free room lighting. Using slat tracking with external blinds, the entry of warm air into the room through sunshine can be avoided and, at the same time, energy costs for lighting the room can be reduced.

Sunshade when the position of the sun is high: The sunshade is only partially closed and automatically moved down only enough so that the sun cannot shine further into the room than specified via the maximum permitted penetration depth. The slats can be set almost vertically without the sun shining directly into the room, as shown in Fig.1.

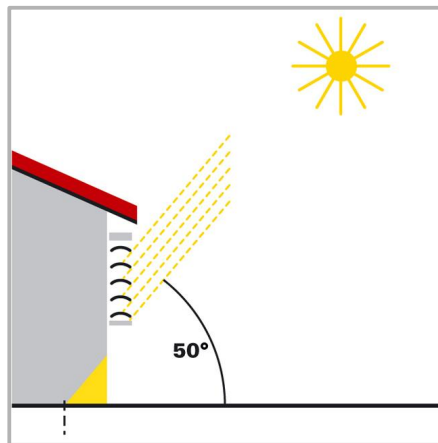

Fig.1

Sunshade when the sun is in a central position: The sunshade is automatically moved down only far enough so that the sun does not exceed the maximum permitted penetration depth in the room. The slats are automatically closed further, so that the sun can not shine directly into the room. Despite that, diffuse daylight can still reach the room and so contribute to the room lighting, as shown in Fig.2.

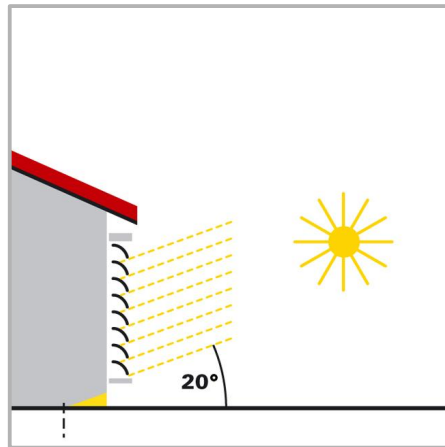

Fig.2

Sunshade when the position of the sun is low: The sunshade is automatically moved down almost fully, so that the sun does not shine too far into the room. The slats are automatically closed further, so that the sun does not shine in directly, as shown in Fig.3.

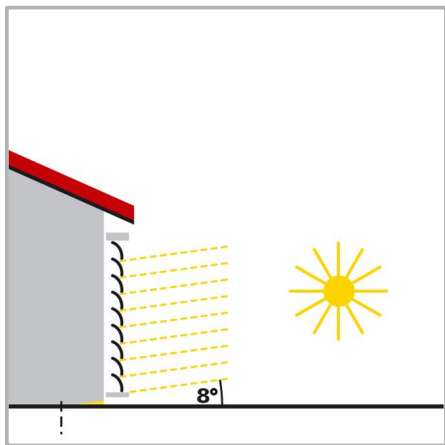

Fig.3

4.10.1.2 Orientation and inclination of the Facade

Top view

The facade orientation corresponds to the angle between the North-south axis and the facade vertical. The angle here is measured in a clockwise direction (North corresponds to 0° , East 90° , South 180° , West 270°), as shown in Fig.1.

The facade orientations result as follows:

Facade 1: α Facade 2: $\alpha+90^\circ$

Facade 3: $\alpha+180^\circ$ Facade 4: $\alpha+270^\circ$

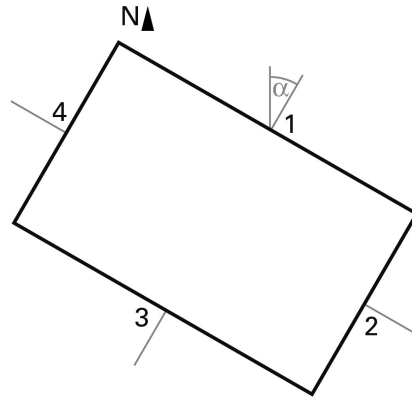

Fig.1

Example: The building in the illustration is turned $\alpha = 30^\circ$ to the east i.e. the Facade alignment is 30° , 120° , 210° and 300° .

Side view: if a facade surface is not oriented vertically, this must be taken into account. A forward inclination of the facade is counted as a positive angle; a back wards inclination (as in the picture) as a negative angle. This also allows a sunshade of a window built into a sloping roof surface to be controlled according to the current position of the sun, as shown in Fig2.

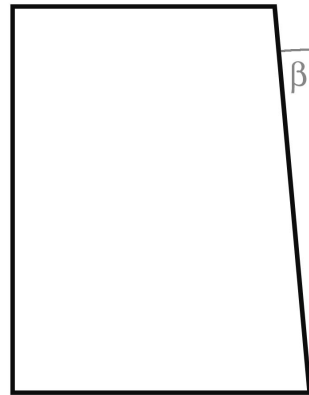

Fig.1

If a Facade is not a flat surface, but rather arched or bent, it must be subdivided into several segments that are controlled separately.

4.10.1.3 Slat type and determination of width and spacing

With slat tracking, a distinction is made between a sunshade or glare protection with horizontal slats and one with vertical slats.

A sunshade with horizontal slats (e.g. external shutter) is typically moved downwards from the top. By contrast, an internal glare protector often consists of thin strips of material (vertical slats), which can be rotated around 180° and are pulled out from one or both sides of the window.

Both types of slat can be adjusted by the KNX GPS weather station so that no direct sunlight falls into the room, but as much diffuse daylight as possible does.

In order for slat tracking to set the slats correctly, their width and spacing from one another must be known.

Horizontal slats

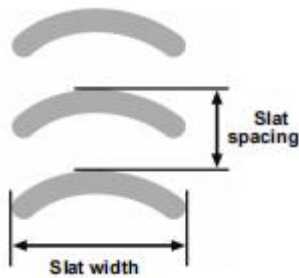

Vertical slats

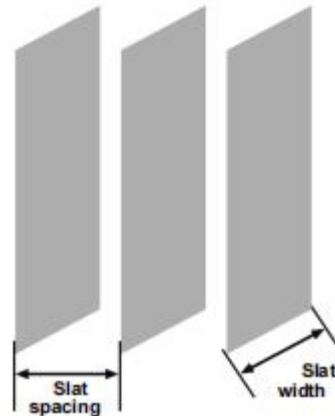

4.10.1.4 Slat position for horizontal slats

For blind drives with 2 limit switches, the upper end position (i.e. sunshade fully open) is controlled via the value 0% or reported as status.

Sunshade opened/upper stop position/0%, as shown in Fig1.

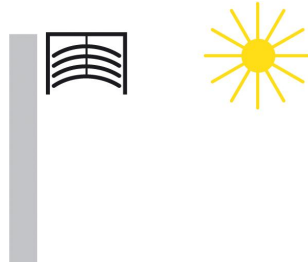

Fig.1

If the lower stop position is to be approached, this is specified to the blinds actuator as sun position "100%" or it will report reaching the lower stop position (i.e. sunshade fully closed) using this value. If blinds are moved down from the upper stop position, the slats first turn into an almost vertical position and the sunshade moves with closed slats to the lower stop position.

If the blinds are in the lower end position and the slats are fully closed, this slat position is described as both "vertical" and "100%". Normally, however, fully closed slats do not have an exactly vertical position ($\alpha = 0^\circ$) but rather form a slight angle with the vertical. This angle must be determined during slat tracking and entered via the parameter "Slat angle in $^\circ$ after position command 100%".

Sunshade and slats closed/lower stop position/Slat position 100% , as shown in Fig2.

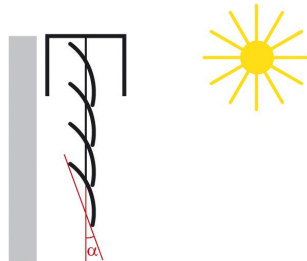

Fig.2

From its "vertical" position (completely closed, 100%) the slats can be adjusted to their horizontal position (fully opened, $\alpha = 90^\circ$). For this, the drive used for the blinds defines whether this adjustment can take place almost continuously in many small steps (as with SMI drives, for example) or whether it is only possible in a few large steps (as with most standard drives).

With standard blinds, there are usually two possible angles that can be entered in the parameter "Slat angle in ° after position command 0%". With both settings, it is important that the associated actuator that controls the blinds is also set accordingly! The first option is to enter this angle $\alpha = 90^\circ$. This setting is adequate for the glare protector.

Slat position horizontal/fully opened/ $\alpha=90^\circ$, as shown in Fig.3.

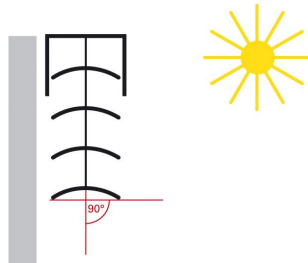

Fig.3

With standard blinds, the slats can be adjusted further via their horizontal position past the point where the slat adjustment ends and the blinds begin to move upwards. The slats then form an angle between 90° and 180° with the vertical. This maximum angle can be entered as a second option in the parameter "Slat angle in ° after position command 0%". With this setting, all angles from approx. 0° to approx. 180° can be approached.

Slat position at the beginning of movement UP, as shown in Fig.4.

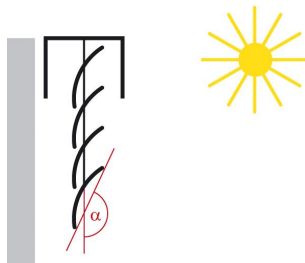

Fig.4

4.10.1.5 Slat position for vertical slats

For an internal blind or privacy screen with vertical slats, the position in which the slats are completely closed is controlled or signalled as slat position 100%. This is the position in which the glare protection is moved from its lateral end position in front of the window. For this, the angle formed by the slats with the direction of movement is $>0^\circ$.

View from the outside: Fully opened vertical slats/slat position 100%, as shown in Fig.1.

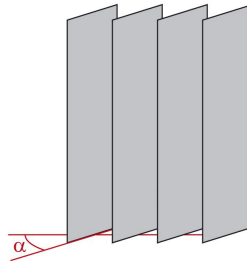

Fig.1

If the slats are fully open, the slats form an angle of 90° with the direction of travel from "Glare protector fully open" to "Glare protector fully closed".

Depending on the blinds used, there are usually two possible angles that can be entered in the parameter "Slat angle in $^\circ$ after position command 0%". With both settings, it is important that the associated actuator that controls the blinds is also set accordingly! The first option is to enter this angle $\alpha = 90^\circ$. This setting is adequate for the glare protector.

Full opened vertical slats/slat position 0%, as shown in Fig.2.



Fig.2

If the glare protector is later retracted (i.e. opened), in the process the vertical slats are turned into a position that is somewhat less than 180°. This maximum angle can be entered as a second option in the parameter "Slat angle in ° after position command 0%". With this setting, all angles from approx. 0° to approx. 180° can be approached.

View from the outside: vertical slats at the beginning of movement UP, as shown in Fig.3.

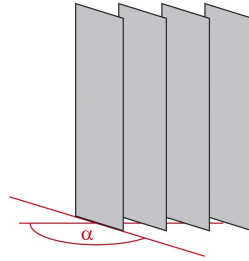

Fig.3

4.10.2 Parameter window "Façade 1/.../8 Actions"

If the brightness condition is fulfilled for the specified duration and the sun position condition is fulfilled, the actions described below are executed. For conditions see chapter 4.10.1.

If for more than	5 sec
Is light enough (brightness condition fulfilled)	
AND	
the sun is shining on the façade (sun position condition fulfilled)	
Then:	
--> Object "Façade 1 status" = 1	
--> Movement position	follows the shadow edge tracking
--> Slat position	75 %
If it is not bright enough	
for more than	10 min
Then:	
Change movement position	<input type="radio"/> No <input checked="" type="radio"/> Yes
--> Movement position	100 %
Change slat position	<input type="radio"/> No <input checked="" type="radio"/> Yes
--> Slat position	1 %
If afterwards	5 sec
it is still not bright enough	
OR	
the sun is no longer shining on the façade	
Then:	
Object "Façade 1 status" = 0	

Change movement position No Yes

--> Movement position %

Change slat position No Yes

--> Slat position %

Transmission behaviour of the objects:

Movement position and slat position send in case of change
 send in case of change and cyclically

Object "Façade 1 status" transmits

Heat protection:

Use heat protection No Yes

Actuation position %

Slat position %

Block and safety:

Behaviour after block react to the last automatic command
 wait for the next automatic command

Blocking object value before 1. communication 0 1

Use safety (lower priority than block) No Yes

Action for safety = 1 do not send positions
 move to safe position (0% / 0%)

Action for safety = 0 react to the last automatic command
 wait for the next automatic command

Fig.4.10.2 Parameter window "Facade 1/.../8 Actions"

Parameter "If for more than"

With the delay time, higher illuminance levels, for example due to a break in the clouds, can be "faded out" for a short time.

Options:

0sec

5sec

...

1.5h

2h

Is light enough (brightness condition fulfilled)

AND

The sun is shining on the facade(sun position condition fulfilled)

Then:

-->Object "Facade 1 status" = 1

Parameter "-->Movement position---follows the shadow edge tracking"

Parameter "-->Slat position"

Actions:

1.Facade status object is set to the value = 1.

2.If shadow edge tracking is activated, the calculated position is approached. Otherwise, the movement position set here is approached.

3.If slat tracking is activated, the calculated position is approached. Otherwise, the slat angle set here is approached.

Options: **0...100%**

If it is not bright enough

Parameter "for more than"

If the brightness condition is no longer fulfilled for the duration specified here, the actions of the "first retraction level" described below are carried out.

With the delay time, lower illuminance levels, for example due to passing clouds, can be "faded out" for a short time.

Options:

0sec

5sec

...

1.5h

2h

Then:

This is the first retraction level that can be used to not yet fully retract the shade. Such an intermediate step is particularly pleasant with large windows, as a little more light is let in, but the sunshade position is also quickly reached again when it gets lighter again shortly afterwards.

Here it is recommended not to change the movement position and to set the slat position to maximum light transmission.

Actions:

1. Movement position can be changed.
2. Slat position can be changed.
3. If no change is selected, then this "first retraction level" is skipped.

Parameter "Change movement position"

This parameter is used to set whether change movement position.

Options:

No

Yes

---Parameter "-->Movement position"

This parameter is visible when previous parameter is selected "yes" .

This parameter is used to set the changed movement position.

Options: **0...100%**

Parameter "Change slat position"

This parameter is used to set whether change movement position.

Options:

No

Yes

---Parameter "-->Slat position"

This parameter is visible when previous parameter is selected "yes" .

This parameter is used to set the changed set slat position.

Options: **0...100%**

Parameter "If afterwards"

If the brightness condition is no longer fulfilled for the duration specified here, the actions described below are carried out. The same applies if the sun position condition is not longer fulfilled.

Options:

0sec

5sec

...

1.5h

2h

it is still not bright enough

OR

The sun is no longer

Shining on the facade

Then:

Object "Facade 1 status" = 0

Actions:

1. Facade status object is set to the value = 0

2. Movement position can be changed.

3. Slat position can be changed.

4. If no change is selected, the shade remains in the current position. This can be used if the shade has already been completely retracted in the "first retraction level" or if the shade is not to be completely retracted for other reasons.

Parameter "Change movement position"

This parameter is used to set whether change movement position.

Options:

No

Yes

—Parameter "-->Movement position"

This parameter is visible when previous parameter is selected "yes".

This parameter is used to set the changed movement position.

Options: **0...100%**

Parameter "Change slat position"

This parameter is used to set whether change movement position.

Options:

No

Yes

—Parameter “-->Slat position”

This parameter is visible when previous parameter is selected “yes” .

This parameter is used to set the changed set slat position.

Options: **0...100%**

Transmission behaviour of the objects:**Parameter “Movement position and slat position”**

The change of a movement or slat position is immediately sent to the bus.

Options:

send in case of change

send in case of change and cyclically

—Parameter “Send cycle(only if facade status = 1)”

This parameter is visible when previous parameter is selected “send in case of change and cyclically” .

For additional periodic sending, both objects “Facade X: Movement position” and “Facade X: slat position” is sent on the bus in a fixed cycle that can be set here.

Options:

5sec

10s

...

1.5h

2h

Parameter “Object “Facade 1 status” transmits”

When the “Facade X status” object is to be sent on the bus is set here.

Options:

on change

on change to 1

on change to 0

on change and periodically

on change to 1 and periodically

on change to 0 and periodically

—Parameter **“Send cycle”**

This parameter is visible when previous parameter is selected “on change and periodically”, “on change to 1 and periodically” and “on change to 0 and periodically”.

When sending periodically, the object “Facade X: status” is sent on the bus in a fixed cycle that can be set here.

Options:

5sec

10s

...

1.5h

2h

Heat protection:

Parameter **“Use heat protection”**

The heat protection function can be used to close shades in order to shield from heat. For this, the heat protection temperature must be activated in section 4.10. See heat protection temperature in chapter 4.10.

Options:

No

Yes

Parameters as follow are visible when “Use heat protection” is selected “yes”.

—Parameter “Actuation position”

Options: **0...100%**

This parameter is used to set the actuation position when use heat protection.

—Parameter “-->Slat position”

This parameter is used to set the slat position when use heat protection.

Options: **0...100%**

Block and safety:

Parameter “Behaviour after block”

The Facade has its own block object (Facade X: Block (1 = blocked)). For example, a manual command (push-button) can lock the automatic shading system.

Options:

react to the last automatic command

wait for the next automatic command

Parameter “Blocking object value before 1. communication”

Before the first communication, i.e. after commissioning or bus voltage restoration, the block can be active (1) or not (0).

Options:

0

1

Parameter “Use safety(lower priority than block)”

In addition, a safety function can be used that moves the shade into the safe position, for example.

Options: **No/Yes**

Parameters as follow are visible when “Use safety(lower priority than block)” is selected “yes”.

—Parameter “Action for safety = 1”

If the safety object is 1, the shade can be retracted or retain its position, but all other automatic actions are ignored.

Options:

do not send position

move to safe position (0% / 0%)

—Parameter “Action for safety = 0”

When the safety status is removed, i.e. when a 0 is received via the safety object, the last stored automatic command can be executed or the next one can be waited for.

Options:

react to the last automatic command

wait for the next automatic command

4.11 Parameter window "Calendar time switch"

The calendar timer defines switching sequences for specific periods during the year. For example, a garden pond pump can only be operated during the summer months.

Use period 1	<input type="radio"/> No	<input checked="" type="radio"/> Yes
Use period 2	<input type="radio"/> No	<input checked="" type="radio"/> Yes
Use period 3	<input type="radio"/> No	<input checked="" type="radio"/> Yes

Fig.4.11 Parameter window "Calendar time switch"

Parameter "Use period 1/2/3"

This parameter sets whether use period 1/2/3/4.

Options:

No

Yes

4.11.1 Parameter window "Calendar clock period 1/2/3"

From:	
Month	January ▼
Day	1 ▲▼
Up to and including:	
Month	January ▼
Day	1 ▲▼
Use sequence 1	<input type="radio"/> No <input checked="" type="radio"/> Yes
Activation time (hours)	0 ▲▼
Activation time (minutes)	0 ▲▼
Deactivation time (hours)	0 ▲▼
Deactivation time (minutes)	0 ▲▼
Switching output sends	on change and periodically ▼
Send cycle	1 min ▼
Use sequence 2	<input type="radio"/> No <input checked="" type="radio"/> Yes
Activation time (hours)	0 ▲▼
Activation time (minutes)	0 ▲▼
Deactivation time (hours)	0 ▲▼
Deactivation time (minutes)	0 ▲▼
Switching output sends	not ▼

Fig.4.11.1 Parameter window "Calendar clock period 1/2/3"

From/Up to and including:

Parameter "Month"

Parameter "Day"

The start date and end date are defined.

Options: **January/February/.../November/December**

Options: **1...31**

Use sequence 1/2

Parameter "Activation time (hours)"

Parameter "Activation time (minutes)"

Parameter "Deactivation time (hours)"

Parameter "Deactivation time (minutes)"

A sequence sets the switch-on and switch-off time for each day of the set period.

Options: **0...23**

Options: **0...59**

Options: **0...23**

Options: **0...59**

Parameter "Switching output sends"

If the switching output of the calendar clock is only used for internal logic, then it does not have to be sent to the bus.

Options:

not

on change

on change to 1

on change to 0

on change and periodically

on change to 1 and periodically

on change to 0 and periodically

—Parameter “Send cycle”

This parameter is visible when previous parameter is selected “on change and periodically”, “on change to 1 and periodically” and “on change to 0 and periodically”.

When sending periodically, the object “Calendar timer time X, Seq. X: switching output” is sent on the bus in a fixed cycle that can be set here.

Options:

5sec

10s

...

1.5h

2h

4.12 Parameter window “Weekly time switch”

The weekly timer offers the possibility of defining different switching times on each day of the week. For example, on weekdays the shutters can be opened every morning and closed again in the evening. 4 sequences per day are available.

Activations:

Monday	<input type="radio"/> No	<input checked="" type="radio"/> Yes
Tuesday	<input type="radio"/> No	<input checked="" type="radio"/> Yes
Wednesday	<input type="radio"/> No	<input checked="" type="radio"/> Yes
Thursday	<input type="radio"/> No	<input checked="" type="radio"/> Yes
Friday	<input type="radio"/> No	<input checked="" type="radio"/> Yes
Saturday	<input type="radio"/> No	<input checked="" type="radio"/> Yes
Sunday	<input type="radio"/> No	<input checked="" type="radio"/> Yes

Fig.4.12 Parameter window “Weekly time switch”

Activations:

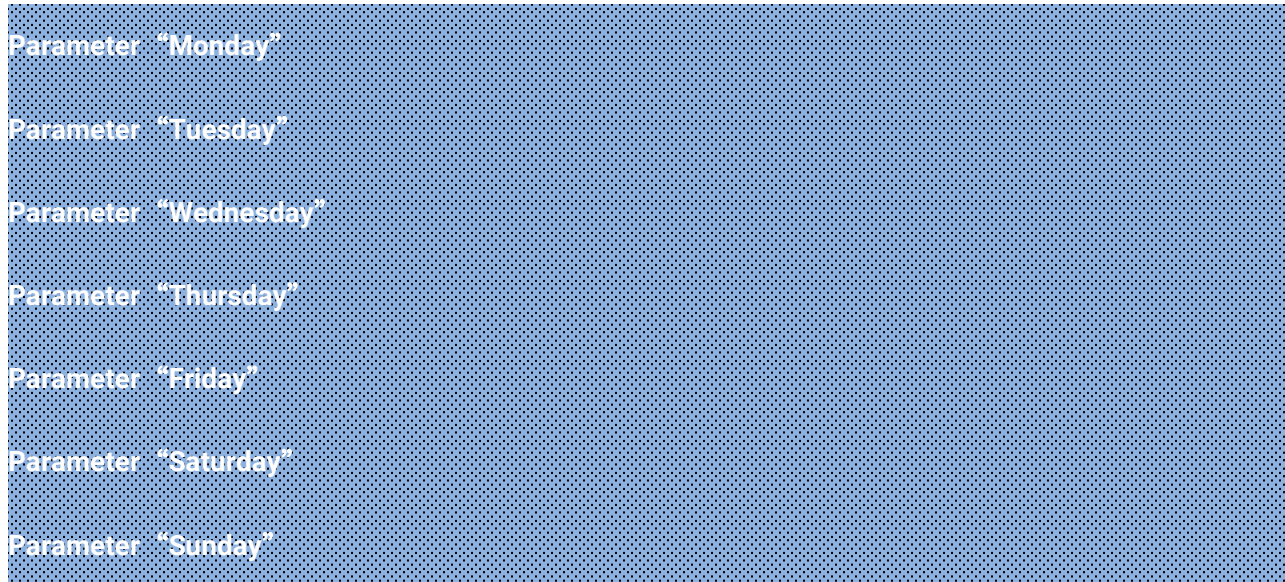

Parameter “Monday”

Parameter “Tuesday”

Parameter “Wednesday”

Parameter “Thursday”

Parameter “Friday”

Parameter “Saturday”

Parameter “Sunday”

This parameter sets whether defining different switching times on each day of the week.

Options: **No/Yes**

4.12.1 Parameter window “Weekly clock Monday/.../Sunday”

Sequence 1:

Activation time
(hours)Activation time
(minutes)Deactivation time
(hours)Deactivation time
(minutes)Sequence 1 should be assigned to OR
link 1 No Yes

Switching output sends

Send cycle

Sequence 2:

Activation time
(hours)Activation time
(minutes)Deactivation time
(hours)Deactivation time
(minutes)Sequence 2 should be assigned to OR
link 2 No Yes

Switching output sends

Send cycle

Sequence 3:

Activation time (hours)

Activation time (minutes)

Deactivation time (hours)

Deactivation time (minutes)

Sequence 3 should be assigned to OR link 3 No Yes

Switching output sends

Send cycle

Sequence 4:

Activation time (hours)

Activation time (minutes)

Deactivation time (hours)

Deactivation time (minutes)

Sequence 4 should be assigned to OR link 4 No Yes

Switching output sends

Send cycle

Fig.4.12.1 Parameter window "Weekly clock Monday/.../Sunday"

Sequence 1/2/3/4:

Use sequence 1

Parameter "Activation time (hours)"

Parameter "Activation time (minutes)"

Parameter "Deactivation time (hours)"

Parameter "Deactivation time (minutes)"

A sequence sets the switch-on and switch-off time for the day of the week.

If, for example, 8:35 is set as the switch-on time, the output switches on the change from 8:34 to 8:35.

If, for example, 15:35 is set as the switch-off time, the output switches off on the change from 15:35 to 15:36.

Options: **0...23**

Options: **0...59**

Options: **0...23**

Options: **0...59**

Parameter "Sequence 1/2/3/4 should be assigned to OR link 1/2/3/4"

A time switching sequence can be assigned to an OR connection. This allows another condition to be added directly in the OR connection in addition to the time. For example, a roller shutter can be opened every morning at 7:00 OR when it is brighter than 10 lux. More in chapter 4.12.1.1.

Options:

No

Yes

Parameter "Switching output sends"

If the switching output of the weekly timer is only used for internal logic, then it does not have to be sent to the bus.

Options:

not

on change

on change to 1

on change to 0

on change and periodically

on change to 1 and periodically

on change to 0 and periodically

—Parameter “Send cycle”

This parameter is visible when previous parameter is selected “on change and periodically”, “on change to 1 and periodically” and “on change to 0 and periodically”.

When sending periodically, the object “Weekly timer [week day] X: switching output” is sent on the bus in a fixed cycle that can be set here.

Options:

5sec

10s

...

1.5h

2h

4.12.1.1 Use of the weekly clock

If the sequence X of a weekday is assigned to the OR connection X, all these assignments are OR-linked with each other. The logical result of this connection can be used as input for an OR logic gate.

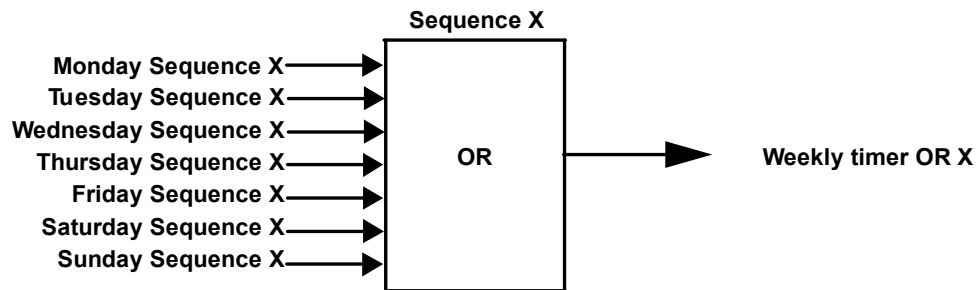

4.13 Parameter window "Logic"

Use logic inputs No Yes

Object value before 1. communication for:

- Logic input 1 0 1
- Logic input 2 0 1
- Logic input 3 0 1
- Logic input 4 0 1
- Logic input 5 0 1
- Logic input 6 0 1
- Logic input 7 0 1
- Logic input 8 0 1
- Logic input 9 0 1
- Logic input 10 0 1
- Logic input 11 0 1
- Logic input 12 0 1
- Logic input 13 0 1
- Logic input 14 0 1
- Logic input 15 0 1
- Logic input 16 0 1

AND logic:

AND logic 1

 not active active

AND logic 2

 not active active

AND logic 3

 not active active

AND logic 4

 not active active

AND logic 5

 not active active

AND logic 6

 not active activeOR logic:

OR logic 1

 not active active

OR logic 2

 not active active

OR logic 3

 not active active

OR logic 4

 not active active

OR logic 5

 not active active

OR logic 6

 not active active

Fig.4.13 Parameter window "Logic"

Parameter "Use logic inputs"

This parameter is used to set whether use logic inputs.

Options:

No

Yes

Parameters as follow are visible when parameter "use logic inputs" is selected "yes".

Object value before 1. communication for:

Parameter "-Logic input 1/.../16"

The device has 16 logic inputs, six AND and six OR logic gates.

For each logic input, the object value can be assigned before the first communication, which is used for the initial commissioning and when the voltage returns.

Options:

0

1

AND/OR logic

Parameter "AND logic 1/.../6"

Parameter "OR logic 1/.../6"

This parameter is used to set whether active and/or logic.

Options:

not active

active

4.13.1 Parameter window "AND/OR logic 1/.../6"

Sun automation example:

The AND logic can be used, for example, to define the conditions for shading, such as a brightness threshold value, and also the reactivation of shading after a wind alarm and blocking by manual operation were included in this example.

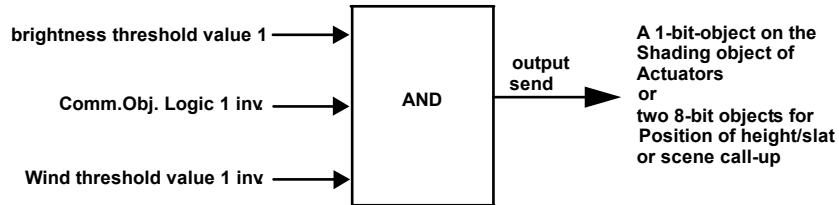

Brightness threshold value 1: Defines the brightness from which shading will occur.

Communications object Logic 1 inverted: Blocking function for the sun automation, e.g. via a button (blocking following manual operation). Logic = 0 released, logic = 1 blocked. The "Communication objects logic inputs" must be enabled and the "Communication object logic 1" must be linked to the push-button via group addresses.

Wind threshold value 1 inverted: The automation activates again once a wind alarm is over (i.e. if the other conditions are fulfilled, shading will occur again).

1st input	do not use
2nd input	do not use
3rd input	do not use
4th input	do not use
Logic output sends	<input type="radio"/> one 1 bit object <input checked="" type="radio"/> two 8 bit objects
Logic output sends	Value (0 ... 255)
if logic = 1 ==> object A value	0
if logic = 0 ==> object A value	0
if logic = 1 ==> object B value	0
if logic = 0 ==> object B value	0
Transmission behaviour	on change of logic and periodically
Transmission cycle	5 sec
Blocking: -----	
Evaluation of the blocking object	<input checked="" type="radio"/> if value 1: block if value 0: release <input type="radio"/> if value 0: block if value 1: release
Blocking object value before 1. communication	<input type="radio"/> 0 <input checked="" type="radio"/> 1
Behaviour of the switching output	
With blocking	send value for logic = 0
With release (incl. 2 seconds release delay)	send value for current logic status

Fig.4.13.1 Parameter window "AND logic 1/.../6"

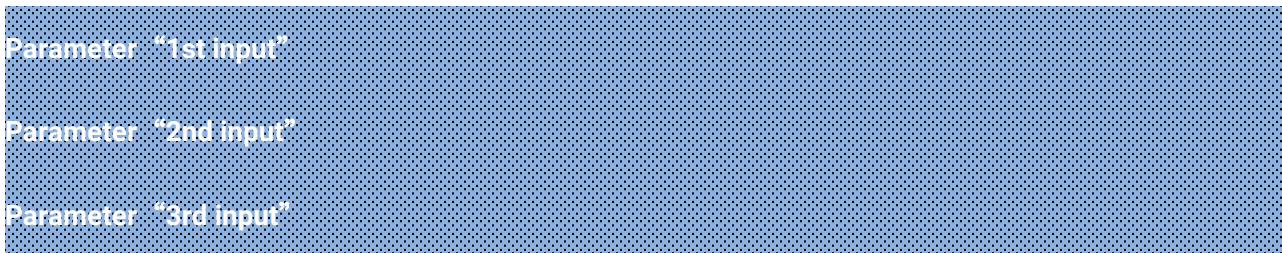

Parameter "4th input"

Four inputs can be defined for each logic gate.

Options:

Do not use

Logic input 1...16

Logic input 1...16 inverted

GPS Malfunction = ON

GPS Malfunction = OFF

Temperature sensor malfunction = ON

Temperature sensor malfunction = OFF

...

Weekly clock OR 1...4

Weekly clock OR 1...4 inverted

Parameter "Logic output sends"

Each logic output can transmit one 1-bit or two 8-bit objects.

Options:

one 1 bit object

two 8 bit objects

Parameters as follow are visible when parameter "logic output sends" is selected "one 1 bit object".

Parameter "If logic = 1 ==> object value"**Parameter "If logic = 0 ==> object value"**

If the output type is a 1-bit-object, both object values are set.

Options: **0/1**

Parameters as follow are visible when parameter “logic output sends” is selected “two 8 bit objects”.

Parameter “Logic output sends”

If the output type is two 8-bit-objects, the object type and object values are set.

Options:

Value (0...255)

Percent (0%...100%)

Angle (0°...360°)

Scene call-up (0...63)

Parameter “If logic = 1 ==> object A value”

Parameter “If logic = 0 ==> object A value”

Parameter “If logic = 1 ==> object B value”

Parameter “If logic = 0 ==> object B value”

If the output type is two 8-bit-objects, the object type and object values are set.

Options:

0...255

0%...100%

0°...360°

0...63

Parameter “Transmission behaviour”

Here you set when the logic output is to be sent to the bus.

Options:

on change of logic

on change of logic to 1

on change of logic to 0

on change of logic and periodically

on change of logic to 1 and periodically

on change of logic to 0 and periodically

—Parameter **“Transmission cycle”**

This parameter is visible when previous parameter is selected “on change of logic and periodically”, “on change of logic to 1 and periodically” and “on change of logic to 0 and periodically”.

When sending periodically, the AND logic object is sent on the bus in a fixed cycle that can be set here.

Options:

5sec

10s

...

1.5h

2h

For example, frost protection can be realised as follows:

AND X input 1 = rain (with 2h switch-off delay)

AND X input 2 = temperature GW1 (= 1 on falling below +1.0°C for example)

AND X output A = 0%

AND X output B = 0%

AND X outputs send on change to 1

Blocking:

Parameter **“Evaluation of the blocking object”**

Each logic gate has its own block object (AND logic X: output block), for which it is set here whether it blocks on receipt of a 1 or 0.

Options:

If value 1: block | if value 0: release

If value 0: block | if value 1: release

Parameter "Blocking object value before 1 communication"

Before the first communication, i.e. after commissioning or bus voltage restoration, the block can be active (1) or not (0).

Options:

0

1

Behaviour of the switching output

Parameter "With blocking"

Parameter "With release(incl.2 seconds release delay)"

The behaviour of the switching output during locking can be set.

Options:

Do not send telegram

Send value for logic = 0

Send value for logic = 1

Options: [Dependent on the "Switching output sends" setting]

Chapter 5 Description of communication object

The communication object is the medium to communicate other device on the bus, namely only the communication object can communicate with the bus.

NOTE: “C” in “Flag” column in the below table means enable the communication function of the object; “W” means value of object can be written from the bus; “R” means the value of the object can be read by the other devices; “T” means the object has the transmission function; “U” means the value of the object can be updated.

5.1 Communication object of “General settings”

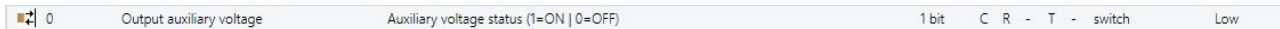

Fig.5.1 Communication object of “General settings”

NO.	Name	Function	Types	Property	DPT
0	Output auxiliary voltage	Auxiliary voltage status (1=ON 0=OFF)	1 Bit	C,R,T	1.001Switch
Send the status of the Auxiliary Voltage (1 = Used; 0 = Not Used).					

Table5.1 Communication object of “General settings”

5.2 Communication object of “GPS settings”

1	Input/Output GPS	GPS date	3 bytes	C R W T U	date	Low
2	Input/Output GPS	GPS time	3 bytes	C R W T U	time of day	Low
3	Input GPS	Date and time request	1 bit	C - W - -	trigger	Low
4	Output GPS	GPS malfunction	1 bit	C R - T -	switch	Low

Fig.5.2 Communication object of “GPS settings”

NO.	Name	Function	Types	Property	DPT
1	Input/Output GPS	GPS date	3 Bytes	R,W,C,T,U	11.001 date
The Date can be read or written here. When setting manually, a maximum interval of 10 seconds between setting the Date and Time is allowed.					
2	Input/Output GPS	GPS time	3 Bytes	R,W,C,T,U	10.001 time of day
The Time can be read or written here. When setting manually, a maximum interval of 10 seconds between setting the Date and Time is allowed.					
3	Input GPS	Date and time request	1 Bit	W,C	1.017 trigger
Writing a 1 to the communication object triggers the device to send its current date and time information to the KNX bus. This is often used to synchronize or retrieve the current time from the device.					
4	Output GPS	GPS malfunction	1 Bit	R,C,T	1.001 switch
If enabled, gps error is recognised = 1 when no value received after a 20min-2hr time. (0 = No Error) Default.					

Table 5.2 Communication object of “GPS settings”

5.3 Communication object of "Location"

5	Output location	Location longitude [°]	4 bytes	C R - T -	angle (degree)	Low
6	Output location	Location latitude [°]	4 bytes	C R - T -	angle (degree)	Low

Fig.5.3 Communication object of "Location"

NO.	Name	Function	Types	Property	DPT
5	Output location	Location longitude [°]	4 Bytes	R,C,T	14.007 angle(degree)
The latitude can be read in degrees [°] (Provided from the GPS).Negative = South, positive = North					
6	Output location	Location latitude [°]	4 Bytes	R,C,T	14.007 angle(degree)
The longitude can be read in degrees [°] (Provided from the GPS).Negative = West, positive = East					

Table 5.3 Communication object of "Location"

5.4 Communication object of “Rain”

7	Output Rain 1	Rain Switching output 1	1 bit	C R - T -	switch	Low
8	Output Rain 2	Rain Switching output 2	1 bit	C R - T -	switch	Low
9	Input Rain	Switch delay to rain	2 bytes	C R W - -	time (s)	Low
10	Input Rain	Switching delay to no rain	2 bytes	C R W - -	time (s)	Low

Fig.5.4 Communication object of “Rain”

NO.	Name	Function	Types	Property	DPT
7	Output Rain 1	Rain Switching output 1	R,C,T	1 Bit	1.001 switch
<p>This Object sends if Rain recognition on the bus (Rain=1; No Rain=0). After reset, (by settings: by change, cyclically).</p>					
8	Output Rain 2	Rain Switching output 2	R,C,T	1 Bit	1.001 switch
<p>(Only valid up to the first call) When High, the system reacts according to predefined time intervals on how it handles the transition back to dry conditions. (Rain=1; No Rain=0)</p>					
9	Input Rain	Switch delay to rain	R,W,C	2 Bytes	9.010 time(s)
<p>The delay can be set (in sec) for Rain recognition for one time.</p>					
10	Input Rain	Switching delay to no rain	R,W,C	2 Bytes	9.010 time(s)
<p>The delay can (in sec) for No Rain recognition for one time.</p>					

Table 5.4 Communication object of “Rain”

5.5 Communication object of “Night”

11	Output Night	Night Switching output	1 bit	C R - T -	switch	Low
12	Input Night	Switching delay on night	2 bytes	C R W - -	time (s)	Low
13	Input Night	Switching delay to non-night	2 bytes	C R W - -	time (s)	Low

Fig.5.5 Communication object of “Night”

NO.	Name	Function	Types	Property	DPT
11	Output Night	Night Switching output	RCT	1 Bit	1.001 switch
Used to detect Night when illumination is less than or equal a set value in Lux.					
12	Input Night	Switching delay on night	RWC	2 Bytes	9.010 time (s)
Used to set the delay time in seconds for sending to the bus when “Night” is detected.					
13	Input Night	Switching delay to non-night	RWC	2 Bytes	9.010 time (s)
Used to set the delay time in seconds for sending to the bus when “non-night” is detected.					

Table 5.5 Communication object of “Night”

5.6 Communication object of "Temperature"

14	Output temperature measurement value	Temperature measured value	2 bytes	C R - T -	temperature (°C)	Low
15	Input temperature measurement value	Temperature measurement value requirement min./max.	1 bit	C - W - -	trigger	Low
16	Output temperature measurement value	Temperature measurement value minimum	2 bytes	C R - T -	temperature (°C)	Low
17	Output temperature measurement value	Temperature measurement value maximum	2 bytes	C R - T -	temperature (°C)	Low
18	Input temperature measurement value	Temperature measurement value reset min./max.	1 bit	C - W - -	trigger	Low
19	Output temperature measurement value	Temperature Sensor Malfunction (0 = OK 1 = NOT OK)	1 bit	C R - T -	switch	Low
20	Input / Output Temperature TV 1	Temperature TV 1 Absolute value	2 bytes	C R W T U	temperature (°C)	Low
21	Input Temperature TV 1	Temperature TV 1 Change (1+ 0: -)	1 bit	C R W - -	switch	Low
22	Input Temperature TV 1	Temperature TV 1 Switching delay from 0 to 1	2 bytes	C R W - -	time (s)	Low
23	Input Temperature TV 1	Temperature TV 1 Switching delay from 1 to 0	2 bytes	C R W - -	time (s)	Low
24	Output Temperature TV 1	Temperature TV 1 Switching output	1 bit	C R - T -	switch	Low
25	Input Temperature TV 1	Temperature TV 1 Switch output block	1 bit	C R W - -	switch	Low

Fig.5.6 Communication object of "Temperature"

NO.	Name	Function	Types	Property	DPT
14	Output temperature measurement value	Temperature measured value	R,C,T	2 Bytes	9.001 temperature (°C)
Measured Value of the internal Sensor.					
15	Input temperature measurement value	Temperature measurement value requirement min./max.	W,C	1 Bit	1.017 trigger
Request the maximum and minimum wind value recorded. Writing a 1 to the communication object triggers the temperature sensor to report its minimum and maximum measured values to the KNX bus.					
16	Output temperature measurement value	Temperature measurement value minimum	R,C,T	2 Bytes	9.001 temperature (°C)
Minimum Measured Value after Reset the bus send it back after requesting a query.					
17	Output temperature measurement value	Temperature measurement value maximum	R,C,T	2 Bytes	9.001 temperature (°C)
Maximum Measured Value after Reset the bus send it back after requesting a query.					
18	Input temperature measurement value	Temperature measurement value reset	W,C	1 Bit	1.017 trigger

		min./max.			
Min./Max values reset after requesting them using the Measurement query. (Obj. No. 15).					
19	Output temperature measurement value	Temperature Sensor Malfunction (0 = OK 1 = NOT OK)	R,C,T	1 Bit	1.001 switch
If enabled, it indicates if the temperature sensor is experiencing an error (1 = malfunction, 0 = no malfunction)					
20	Input / Output Temperature TV 1	Temperature TV 1 Absolute value	R,W,C, T,U	2 Bytes	9.001 temperature (°C)
Reference point of setting or reading the threshold value 1.					
21	Input Temperature TV 1	Temperature TV 1 Change (1:+ 0: -)	R,W,C	1 Bit	1.001 switch
Used to increment=1 or decrement=0 the Temp threshold value 1.					
22	Input Temperature TV 1	Temperature TV 1 Switching delay from 0 to 1	R,W,C	2 Bytes	9.010 time (s)
Used to set the delay time in seconds for the switching output to change from 0 to 1 (after the measured value is above the threshold).					
23	Input Temperature TV 1	Temperature TV 1 Switching delay from 1 to 0	R,W,C	2 Bytes	9.010 time (s)
Used to set the delay time in seconds for the switching output to change from 1 to 0 (after the measured value falls below the threshold)					
24	Output Temperature TV 1	Temperature TV 1 Switching output	R,C,T	1 Bit	1.001 switch

Used to trigger actions if the measured value is above or under (considering the time delays) temperature threshold 1. (The telegram value is defined by the parameter "Output is at (TV=threshold value) (SD=Switching distance)")

25	Input Temperature TV 1	Temperature TV 1 Switch output block	R,W,C	1 Bit	1.001 switch
-----------	-----------------------------------	---	--------------	--------------	---------------------

Used to receive a binary state to (block = 1 or allow = 0 "default values") the switching output based on temperature threshold 1.

Table 5.6 Communication object of "Temperature"

5.7 Communication object of "Wind"

44	Output wind measurement	Wind measurement	2 bytes	C R - T -	speed (m/s)	Low
45	Input wind measurement value	Wind measurement value requirement max.	1 bit	C - W - -	trigger	Low
46	Output wind measurement	Maximum wind measurement value	2 bytes	C R - T -	speed (m/s)	Low
47	Input wind measurement value	Wind measurement value reset max.	1 bit	C - W - -	trigger	Low
49	Input / Output Wind TV 1	Wind TV 1 Absolute value	2 bytes	C R W T U	speed (m/s)	Low
50	Input Wind TV 1	Wind TV 1 Change (1:+ 0:-)	1 bit	C R W - -	switch	Low
51	Input Wind TV 1	Wind TV 1 Switching delay from 0 to 1	2 bytes	C R W - -	time (s)	Low
52	Input Wind TV 1	Wind TV 1 Switching delay from 1 to 0	2 bytes	C R W - -	time (s)	Low
53	Output Wind TV 1	Wind TV 1 Switching output	1 bit	C R - T -	switch	Low
54	Input Wind TV 1	Wind TV 1 Switch output block	1 bit	C R W - -	switch	Low

Fig.5.7 Communication object of "Wind"

NO.	Name	Function	Types	Property	DPT
44	Output wind measurement	Wind measurement	R,CT	2 Bytes	9.005 speed (m/s)
Measured value of wind speed in m/s.					
45	Input wind measurement value	Wind measurement value requirement max.	W,C	1 Bit	1.017 trigger
Request the maximum wind value recorded. Writing a 1 to the communication object triggers the wind sensor to report its maximum measured value to the KNX bus.					
46	Output wind measurement	Maximum wind measurement value	R,C,T	2 Bytes	9.005 speed (m/s)
Max wind speed measured in m/s.					
47	Input wind measurement value	Wind measurement value reset max.	W,C	1 Bit	1.017 trigger
Reset Max wind value recorded.					
48	Output wind sensor	Wind Sensor Malfunction (0 = OK 1 = NOT OK)	R,C,T	1 Bit	1.001 switch
If enabled, it indicates if the Wind sensor is experiencing a malfunction (1 = malfunction, 0 = no malfunction).					
49	Input / Output Wind TV 1	Wind TV 1 Absolute value	R,W,C,	2 Bytes	9.005 speed (m/s)

			T,U		
Reference point of setting or reading the wind threshold value 1.					
50	Input Wind TV 1	Wind TV 1 Change (1:+ 0: -)	R,W,C	1 Bit	1.001 switch
Used to increment=1 or decrement=0 the wind threshold value 1.					
51	Input Wind TV 1	Wind TV 1 Switching delay from 0 to 1	R,W,C	2 Bytes	9.010 time (s)
Used to set the delay time in seconds for the switching output to change from 0 to 1 (after the measured value falls below the threshold).					
52	Input Wind TV 1	Wind TV 1 Switching delay from 1 to 0	R,W,C	2 Bytes	9.010 time (s)
Used to set the delay time in seconds for the switching output to change from 1 to 0 (after the measured value falls below the threshold).					
53	Output Wind TV 1	Wind TV 1 Switching output	R,C,T	1 Bit	1.001 switch
Used to trigger actions if the measured value is above or under (considering the time delays) wind threshold 1(The telegram value is defined by the parameter "Output is at (TV=threshold value) (SD=Switching distance)").					
54	Input Wind TV 1	Wind TV 1 Switch output block	R,W,C	1 Bit	1.001 switch
Used to receive a binary state to (block = 1 or allow = 0 "default values") the switching output based on wind threshold 1.					

Table 5.7 Communication object of "Wind"

5.8 Communication object of "Brightness"

67	Output brightness measurement	Brightness measurement	2 bytes	C R - T -	lux (Lux)	Low
68	Input / Output Brightness TV 1	Brightness TV 1 Absolute value	2 bytes	C R W T U	lux (Lux)	Low
69	Input Brightness TV 1	Brightness TV 1 Change (1:+ 0: -)	1 bit	C R W - -	switch	Low
70	Input Brightness TV 1	Brightness TV 1 Switching delay from 0 to 1	2 bytes	C R W - -	time (s)	Low
71	Input Brightness TV 1	Brightness TV 1 Switching delay from 1 to 0	2 bytes	C R W - -	time (s)	Low
72	Output Brightness TV 1	Brightness TV 1 Switching output	1 bit	C R - T -	switch	Low
73	Input Brightness TV 1	Brightness TV 1 Switch output block	1 bit	C R W - -	switch	Low

Fig.5.8 Communication object of "Brightness"

NO.	Name	Function	Types	Property	DPT
67	Output brightness measurement	Brightness measurement	R,C,T	2 Bytes	9.004 lux (Lux)
Send the highest currently measured value of the five internal Bright. sensors on the bus.					
68	Input / Output Brightness TV 1	Brightness TV 1 Absolute value	R,W,C,T,U	2 Bytes	9.004 lux (Lux)
Reference point of setting or reading the bright. threshold value 1.					
69	Input Brightness TV 1	Brightness TV 1 Change (1:+ 0: -)	R,W,C	1 Bit	1.001 switch
Used to increment=1 or decrement=0 the bright. threshold value 1.					
70	Input Brightness TV 1	Brightness TV 1 Switching delay from 0 to 1	R,W,C	2 Bytes	9.010 time (s)
Used to set the delay time in seconds for the switching output to change from 0 to 1 (after the measured value falls below the threshold).					
71	Input Brightness TV 1	Brightness TV 1 Switching delay from 1 to 0	R,W,C	2 Bytes	9.010 time (s)
Used to set the delay time in seconds for the switching output to change from 0 to 1 (after the measured value falls below the threshold).					
72	Output Brightness TV 1	Brightness TV 1 Switching output	R,C,T	1 Bit	1.001 switch

Used to trigger actions if the measured value is above or under (considering the time delays) threshold 1 (The telegram value is defined by the parameter "Output is at (TV=threshold value) (SD=Switching distance)").

73	Input Brightness TV 1	Brightness TV 1 Switch output block	R,W,C	1 Bit	1.001 switch
----	------------------------------	--	--------------	--------------	---------------------

Used to receive a binary state to (block = 1 or allow = 0 "default values") the switching output based on brightness threshold 1.

Table 5.8 Communication object of "Brightness"

5.9 Communication object of "Dawn"

92	Input / Output Twilight TV 1	Twilight TV 1 Absolute value	2 bytes	C R W T U	lux (Lux)	Low
93	Input Twilight TV 1	Twilight TV 1 Change (1:+ 0: -)	1 bit	C R W - -	switch	Low
94	Input Twilight TV 1	Twilight TV 1 Switching delay from 0 to 1	2 bytes	C R W - -	time (s)	Low
95	Input Twilight TV 1	Twilight TV 1 Switching delay from 1 to 0	2 bytes	C R W - -	time (s)	Low
96	Output Twilight TV 1	Twilight TV 1 Switching output	1 bit	C R - T -	switch	Low
97	Input Twilight TV 1	Twilight TV 1 Switch output block	1 bit	C R W - -	switch	Low

Fig.5.9 Communication object of "Dawn"

NO.	Name	Function	Types	Property	DPT
92	Input / Output Twilight TV 1	Twilight TV 1 Absolute value	R,W,C ,T,U	2 Bytes	9.004 lux (Lux)
Reference point of setting or reading Twilight threshold value 1.					
93	Input Twilight TV 1	Twilight TV 1 Change (1:+ 0: -)	R,W,C	1 Bit	1.001 switch
Used to increment=1 or decrement=0 the Twilight threshold value 1.					
94	Input Twilight TV 1	Twilight TV 1 Switching delay from 0 to 1	R,W,C	2 Bytes	9.010 time (s)
Used to set the delay time in seconds for the switching output to change from 0 to 1 (after the measured value falls below the threshold).					
95	Input Twilight TV 1	Twilight TV 1 Switching delay from 1 to 0	R,W,C	2 Bytes	9.010 time (s)
Used to set the delay time in seconds for the switching output to change from 1 to 0 (after the measured value falls below the threshold).					
96	Output Twilight TV 1	Twilight TV 1 Switching output	R,C,T	1 Bit	1.001 switch
Used to trigger actions if the measured value is above or under (considering the time delays) threshold 1(The telegram value is defined by the parameter "Output is at (TV=threshold value) (SD=Switching distance)").					
97	Input Twilight TV 1	Twilight TV 1 Switch output block	R,W,C	1 Bit	1.001 switch
Used to receive a binary state to (block = 1 or allow = 0 "default values") the switching output based on twilight threshold 1.					

Table 5.9 Communication object of "Dawn"

5.10 Communication object of "Shading"

110	Output sun position	Sun position direction of the sun [°]	4 bytes	C R - T -	angle (degree)	Low
111	Output sun position	Sun position height of the sun [°]	4 bytes	C R - T -	angle (degree)	Low
112	Output sun position	Sun position direction of the sun [°]	2 bytes	C R - T -	humidity (%)	Low
113	Output sun position	Sun position height of the sun [°]	2 bytes	C R - T -	humidity (%)	Low
114	Output Façades	Façades Thermal insulation status	1 bit	C R - T -	switch	Low
115	Output Façade 1	Façade 1 Status	1 bit	C R - T -	switch	Low
116	Output Façade 1	Façade 1 Movement position [%]	1 byte	C R - T -	percentage (0..100...)	Low
117	Output Façade 1	Façade 1 Slat position [%]	1 byte	C R - T -	percentage (0..100...)	Low
118	Input Façade 1	Façade 1 Block (1 = blocked)	1 bit	C - W - -	switch	Low
119	Input Façade 1	Façade 1 Safety (1 = active)	1 bit	C - W - -	switch	Low

Fig.5.10 Communication object of "Shading"

NO.	Name	Function	Types	Property	DPT
110	Output sun position	Sun position azimuth [°]	R,C,T	4 Bytes	14.007 angle (degree)
Received Value of Sun Azimuth Angle in Degrees (4 bytes floating point).					
111	Output sun position	Sun position elevation [°]	R,C,T	4 Bytes	14.007 angle (degree)
Received Value of Sun Elevation Angle in Degrees (4 bytes floating point).					
112	Output sun position	Sun position azimuth [°]	R,C,T	2 Bytes	9.007 humidity (%)
Received Value of Sun Azimuth Angle in Degrees (2 bytes floating point).					
113	Output sun position	Sun position elevation [°]	R,C,T	2 Bytes	9.007 humidity (%)
Received Value of Sun Elevation Angle in Degrees (2 bytes floating point).					
114	Output Facades	Facades Thermal insulation status	R,C,T	1 Bit	1.001Switch
Status of Heat Protection function. (1= Heat Protection function is active, 0= Heat Protection function is deactivated).					
115	Output Facade 1	Facade 1 Status	R,C,T	1 Bit	1.001 switch
Indicates if facade 1 channel is activated or not.					
116	Output Facade 1	Facade 1 Movement position [%]	R,C,T	1 Byte	5.001 percentage (0...100%)
Send the Movement position on the bus to control the actuators of the facade 1.					

117	Output Facade 1	Facade 1 Slat position [%]	R,C,T	1 Byte	5.001 percentage (0...100%)
Send the Slats position on the bus to control the actuators of the facade 1.					
118	Input Facade 1	Facade 1 Block (1 = blocked)	W,C	1 Bit	1.001 switch
If activated = 1 the facade 1 can't be controlled. (Default).					
119	Input Facade 1	Facade 1 Safety (1 = active)	W,C	1 Bit	1.001 switch
If the safety object is 1, the facade 1 can be retracted or retain its position, but all other automatic actions are ignored.					

Table 5.10 Communication object of "Shading"

5.11 Communication object of “Calendar time switch”

155 Output.Calendar time switch Period 1, Seq. 1 Calendar time switch Period 1, Seq. 1 Switching output 1 bit C R - T - switch Low

Fig.5.11 Communication object of “Calendar time switch”

NO.	Name	Function	Types	Property	DPT
155	“Output Calendar time switch Period 1, Seq. 1”	“Calendar time switch Period 1, Seq. 1 Switching output”	R,C,T	1 Bit	1.001 switch
<p>If the CTP 1 Seq 1 is active and the current time falls within the defined time range, the output is high (1); If the period is not active or the current time is outside the defined time range, the output is low (0).</p>					

Table 5.11 Communication object of “Calendar time switch”

5.12 Communication object of “Weekly time switch”

161	Output Weekly time switch Monday 1	Weekly time switch Monday 1 Switching output	1 bit	C R - T - switch	Low
162	Output Weekly time switch Monday 2	Weekly time switch Monday 2 Switching output	1 bit	C R - T - switch	Low
163	Output Weekly time switch Monday 3	Weekly time switch Monday 3 Switching output	1 bit	C R - T - switch	Low
164	Output Weekly time switch Monday 4	Weekly time switch Monday 4 Switching output	1 bit	C R - T - switch	Low

Fig.5.12 Communication object of “Weekly time switch”

NO.	Name	Function	Types	Property	DPT
161/.../164	Output Weekly time switch Monday 1/.../4	Weekly time switch Monday 1/.../4 Switching output	R,C,T	1 Bit	1.001 switch
Value is High(1) when Monday Seq.1/.../4 is active & Value is Low(0) when Monday Seq.1/.../4 is inactive .					

Table 5.12 Communication object of “Weekly time switch”

5.13 Communication object of "Logic"

189	Input logic input 1	Logic input 1	1 bit	C - W - - switch	Low
190	Input logic input 2	Logic input 2	1 bit	C - W - - switch	Low
191	Input logic input 3	Logic input 3	1 bit	C - W - - switch	Low
192	Input logic input 4	Logic input 4	1 bit	C - W - - switch	Low
193	Input logic input 5	Logic input 5	1 bit	C - W - - switch	Low
194	Input logic input 6	Logic input 6	1 bit	C - W - - switch	Low
195	Input logic input 7	Logic input 7	1 bit	C - W - - switch	Low
196	Input logic input 8	Logic input 8	1 bit	C - W - - switch	Low
197	Input logic input 9	Logic input 9	1 bit	C - W - - switch	Low
198	Input logic input 10	Logic input 10	1 bit	C - W - - switch	Low
199	Input logic input 11	Logic input 11	1 bit	C - W - - switch	Low
200	Input logic input 12	Logic input 12	1 bit	C - W - - switch	Low
201	Input logic input 13	Logic input 13	1 bit	C - W - - switch	Low
202	Input logic input 14	Logic input 14	1 bit	C - W - - switch	Low
203	Input logic input 15	Logic input 15	1 bit	C - W - - switch	Low
204	Input logic input 16	Logic input 16	1 bit	C - W - - switch	Low
205	Output AND logic 1	AND logic 1 1 bit switching output	1 bit	C R - T - switch	Low
208	Input AND logic 1	AND logic 1 Output block	1 bit	C - W - - switch	Low
230	Output OR logic 1	OR logic 1 8 bit output A	1 byte	C R - T - counter pulses (0....	Low
231	Output OR logic 1	OR logic 1 8 bit output B	1 byte	C R - T - counter pulses (0....	Low
232	Input OR logic 1	OR logic 1 Output block	1 bit	C - W - - switch	Low
253	Output software version	Software version	2 bytes	C R - T - DPT version	Low

Fig.5.13 Communication object of "Logic"

NO.	Name	Function	Types	Property	DPT
189	Input logic input 1	Logic input 1/.../16	W,C	1 Bit	1.001 switch
Logical input 1 of type bit to be used in logical functions.					
205	Output AND logic 1	AND logic 1 1 bit switching output	R,C,T	1 Bit	1.001 switch
Output of And Logic 1 according to 4 available inputs.					
206	Output AND logic 1	AND logic 1 8 bit output A	R,C,T	1 Byte	depending on setting
Output A of And Logic 1 (1Byte Value set in the parameters).					
207	Output AND logic 1	AND logic 1 8 bit output B	R,C,T	1 Byte	depending on setting
Output B of And Logic 1 (1Byte Value set in the parameters).					
229	Output OR logic 1	OR logic 1 bit switching output	R,C,T	1 Bit	1.001 switch
Output of OR Logic 1 according to 4 available inputs.					
230	Output OR logic 1	OR logic 1 8 bit output A	R,C,T	1 Byte	depending on setting
Output A of OR Logic 1 (1Byte Value set in the parameters).					
231	Output OR logic 1	OR logic 1 8 bit output B	R,C,T	1 Byte	depending on setting

Output B of OR Logic 1 (1Byte Value set in the parameters)					
232	Input OR logic 1	OR logic 1 Output block	W,C	1 Bit	1.001 switch
Used to block the output of OR Logic 1 (1 = block & 0 = released). Default.					

Table 5.13 Communication object of "Logic"