

# K-BUS Colour Touch Panel 5.0"

## User manual-Ver. 1

CHTF-05/01.1

Intelligent installation systems



# Contents

---

|  |           |
|--|-----------|
| <b>1. Overview</b>                                 | <b>3</b>  |
| <b>2. Technical data</b>                           | <b>4</b>  |
| <b>3. Dimension and circuit diagram</b>            | <b>5</b>  |
| 3.1 Dimension diagram                              | 5         |
| 3.2 Circuit diagram                                | 5         |
| <b>4. Project design and programming</b>           | <b>6</b>  |
| <b>5. Parameter setting description in the ETS</b> | <b>7</b>  |
| 5.1. Parameter window “General Setting”            | 7         |
| 5.2. Parameter window “Lighting”                   | 14        |
| 5.3. Parameter window “Blind/Shutter”              | 16        |
| 5.4. Parameter window “Scene”                      | 18        |
| 5.5. Parameter window “HVAC”                       | 19        |
| 5.6. Parameter window “Customize”                  | 29        |
| 5.7. Parameter window “Audio”                      | 31        |
| 5.8. Parameter window “Air condition”              | 33        |
| 5.9. Parameter window “Security”                   | 36        |
| 5.10. Parameter window “RGB LED dimming”           | 38        |
| 5.11. Parameter window “Logic”                     | 39        |
| <b>6. Description of communication object</b>      | <b>41</b> |
| 6.1. Communication object “General Setting”        | 41        |
| 6.2. Communication object “Lighting”               | 42        |
| 6.3. Communication object “Blind/Shutter”          | 43        |
| 6.4. Communication object “Scene”                  | 44        |
| 6.5. Communication object “HVAC”                   | 44        |
| 6.6. Communication object “Customize”              | 46        |
| 6.7. Communication object “Audio”                  | 46        |
| 6.8. Communication object “Air condition”          | 48        |
| 6.9. Communication object “Security”               | 50        |
| 6.10. Communication object “RGB LED dimming”       | 51        |
| 6.11. Communication object “Logic”                 | 51        |
| <b>7. Appendix</b>                                 | <b>52</b> |
| 7.1 The main interface                             | 52        |
| 7.2 Password interface                             | 53        |
| 7.3 Settings interface                             | 53        |
| 7.4 Lighting control interface                     | 54        |
| 7.5 Shutter / blind control interface              | 55        |
| 7.6 Scene control interface                        | 56        |
| 7.7 HVAC control interface                         | 57        |
| 7.8 Sending of customize value interface           | 57        |
| 7.9 Audio control interface                        | 58        |
| 7.10 Air conditioning control interface            | 59        |
| 7.11 Security setting interface                    | 60        |
| 7.12 RGB LED dimming interface                     | 61        |

## 1. Overview

The Colour Touch Panel 5.0" (hereinafter referred to as TFT) is used to display status and control various devices in the EIB/KNX system. When you touch some graphic button in the TFT operation system, the TFT will execute a predefined function, such as switch lighting, scene control or blinds/shutter control etc. The TFT can display frame via LCD and make warning tone compare with common button panel, and the users can operation the TFT system easily and clearly via interactive interface.

The TFT is mainly applied in the home and building control system, which can be mounted on a conventional 86 boxes. First, fix the mounted iron stents into the 86 boxes, and then fix the well-connected TFT to the iron stents and stick fast by pushing it downward. If you want to dismantle it, then push it oppositely and pull it out gently. Please note——program the physical address before installation.

This manual provides detailed technical information about the TFT for users as well as assembly and programming details, and explains how to use the TFT by the application examples.

The TFT is connected to the bus via the EIB connection terminals and need a 30V DC additional supply voltage. It is available to assign the physical address and set the parameters by Engineering design tools ETS with VD3/VD4 (higher than edition ETS3).

The TFT functions are summarized as following:

- Capacitive touch screen, color display
- Switching and dimming
- Control of blinds and shutters
- Sending of values, e.g. water line, brightness
- Recall and storage scene
- Temperature measure and control function
- RGB LED dimming and logic function
- Background music control and security control
- Air condition control
- Can display indoor and outdoor temperature
- Operating lock and proximity function

## 2. Technical data

|                              |                            |   |
|------------------------------|----------------------------|---|
| <b>Power supply</b>          | Bus voltage                | 21-30V DC, via the EIB  |
|                              | External power supply      | 20-30V DC   |
|                              | Bus current consumption    | <12mA   |
|                              | Bus power consumption      | <360mW  |
|                              | External power consumption | <6W   |
| <b>Connections</b>           | EIB / KNX                  | Via bus connection terminal(black/red)                                |
|                              | External power supply      | Via bus connection terminal(grey/yellow)                              |
|                              | Cable cross-section        | Single core 0.2—6.0mm <sup>2</sup><br>Multi core 0.2—4mm <sup>2</sup> |
| <b>Operating and display</b> | Programming LED and button | For assignment of the physical address                                |
|                              | Green LED flashing         | Indicate the device running normally(OK)                              |
|                              | Screen reset button        | Restart TFT display system  |
| <b>Temperature</b>           | Operation                  | -5 °C ... + 45 °C   |
|                              | Storage                    | -25 °C ... + 55 °C  |
|                              | Transport                  | - 25 °C ... + 70 °C   |
| <b>Ambient condition</b>     | Humidity                   | <93%, except dewing   |
| <b>Installation</b>          | Wall-mounted type          |   |
| <b>Dimensions</b>            | 145.8×91×34.5mm            |   |
| <b>Weight</b>                | 0.3KG                      |   |

### 3. Dimension and circuit diagram

#### 3.1 Dimension diagram

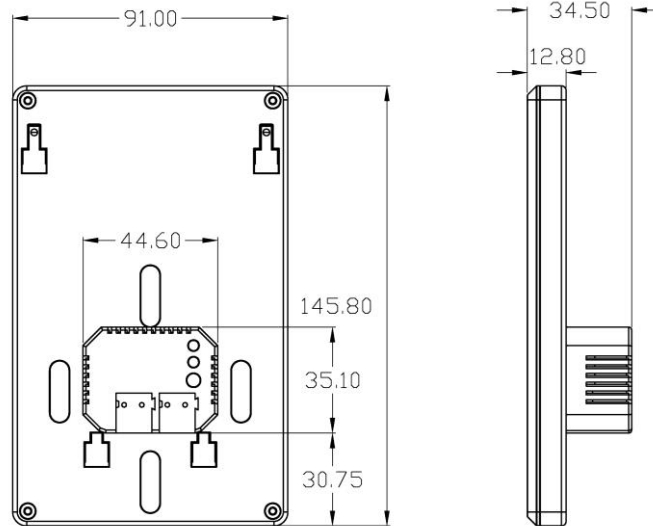

#### 3.2 Circuit diagram

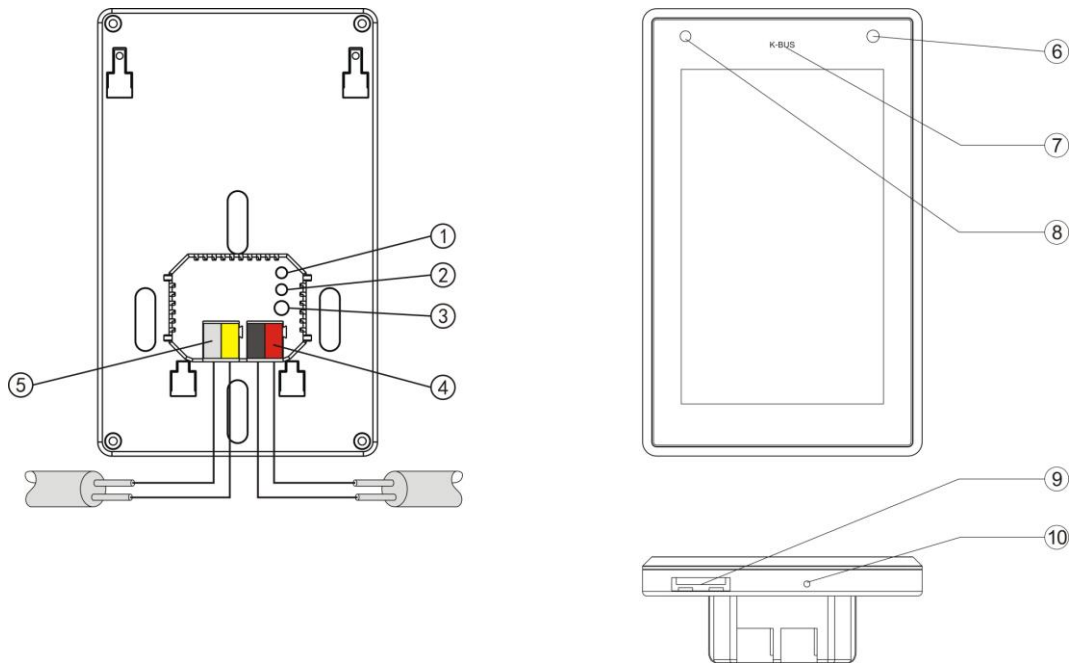

- ① Reset button, reset screen display, but not reset application
- ② Programming button
- ③ Red LED for entering the physical address, green LED for application process normally running
- ④ KNX / EIB bus connection terminal

- ⑤ External power supply connection terminal
- ⑥ IR transmitter probe, proximity function (now unavailable)
- ⑦ Indicator LED
- ⑧ IR receiver probe, proximity function (now unavailable)
- ⑨ SD card
- ⑩ Internal temperature sensor

---

## 4. Project design and programming

| Application program     | Max. number of communication objects | Max. number of group address | Max. number of associations |
|-------------------------|--------------------------------------|------------------------------|-----------------------------|
| Colour Touch Panel 5.0" | 208                                  | 250                          | 250                         |

Overview of the functions:

### General setting

General functions include system menu language, warning tone, indicator LED, proximity function, operation block, screen saver, backlight brightness, show date/time, show indoor and outdoor temperature.

### Lighting

The function can be used for switching or dimming lighting, provide up to 18 lightings control. Its dimming way uses absolute dimming.

### Blinds and shutter

The function can be used for movement/lamella adjustment of a blind or a shutter, provide up to 6 blinds/shutters control.

### Scene

The function is used for recalling and storing a scene, provide up to 18 scenes control.

### HVAC control

HVAC can be used for controlling an actuator on the bus to regulate room temperature according to the room of the use or requirements of the users.

### Sending of customize values

The function can be used for sending values of different data type. A group values can be send to bus via an operation, which include three values that may be different data type. The application provides up to 18 customize group settings.

### Audio

With the application, background music player can be controlled via bus.

### Air condition

The function is similar to functions of the air-condition remote control. With the application,

the TFT can control air condition via IR transmitter on the bus, for example, the TFT send a control telegram to the IR transmitter, the IR transmitter will send a message with the function code to the air-condition, thus the air-condition can be turned on or off, switched to different operation mode, or regulated wind speed etc via the application.

### **Security**

With the application, homeowners can execute a arming when leave home. Such as turn on warning system, turn on camera monitor etc. Homeowners can execute a disarming when back home, disable the warning system. The application provides up to 6 security settings.

### **RGB LED dimming**

The function can be used for dimming RGB LED. Its dimming way uses absolute dimming.

### **Logic function**

The function has two logic inputs: input1 and input2, provide three standard logic operation: AND, OR, XOR. “Input1” makes logic operation with “input2”, and then the result is sent via “output”. For example, via the application control staircase lighting, if you want to turn on the lighting when anyone pass the staircase. But it is not necessary to carry out this action if it is enough brightness, unless it is dark. Therefore, there are two conditions to decide whether the lighting is turned on, now you can take the two conditions as logic input, and the lighting will be automatically turned on if they meet demand. The application provides up to 5 logic operation functions.

## **5. Parameter setting description in the ETS**

### **5.1. Parameter window “General Setting”**

Parameter window “General Setting” can be shown in fig.5.1. Here set general function about TFT operation system, such as time, temperature, backlighting, screen saver, warning tone etc.

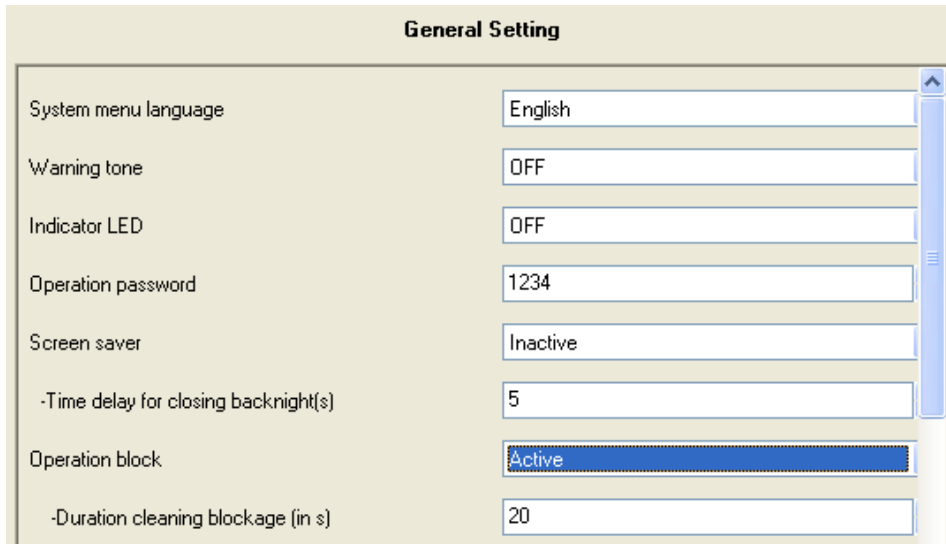

Fig. 5.1 parameter window “General Setting” (1)

**Parameter “System menu language”**

This parameter is used to set menu language of the TFT operation system, there are 16 languages can be selected for the user.

Currently, only support Chinese and English.

**Parameter “Warning tone”**

This parameter is used to set whether the warning tone is enabled. If enabled, the TFT will make a sound when its graphic button is operated. Options:

- Off
- On

**Parameter “Indicator LED”**

This parameter is used to set whether the indicator LED (K-BUS logo) is turned on. If turned on, the place where the TFT is mounted is known easily in the evening. Options:

- Off
- On

**Parameter “Operation password”**

This parameter is used to set operation password. After the TFT executes block operation, if you want to operate the TFT again, you need enter into the password. It also can be used to disarm when the security is activated (see chapter 5.9). If you want to open the setting window, you also need enter into it. Option: 0...999999

**Parameter “Screen saver”**

This parameter is used to set whether screen saver of the TFT is activated. Options:

- Inactive
- Clock
- Album

If selecting “clock”, when the TFT enters into the screen saver, the clock will be shown in the screen, and the backlight of screen will also be not switched off. At this time, the backlight is set in



the follow parameter “Backlighting day/night when does not under operating”.

If selecting “album”, when the TFT enters into the screen saver, electronic photo album pictures in a SD card will be shown in the screen, and the backlight of screen will also be not switched off. At this time, the backlight is set in the follow parameter “Backlighting day/night when does not under operating”. Please note the electronic pictures must be stored in the folder “Album”, otherwise when screen saver, the TFT will show the pictures with application program.

If selecting “inactive”, the screen saver function will be inactivated, and the delay for closing backlight has passed, the backlight of screen is set in the follow parameter “backlighting day/night when does not under operating (%)”.

— **Parameter “Time delay for closing backlight(s)”**

This parameter is visible if the option “inactive” has been selected with the parameter “screen saver”. It is used to set how long time delay to close the backlight of screen. I.e. after nobody operates the TFT, and the delay has passed, the backlight of screen will be changed to the brightness that is set in the follow parameter “backlighting day/night when does not under operating (%)”. Option: 5...6000 s

— **Parameter “Switch-on delay of the screen saver(s)”**

This parameter is visible if the option “inactive” has not been selected with the parameter “screen saver”. It is used to set how long time delay to switch on the screen saver. I.e. after nobody operates the TFT, and the delay has passed, the TFT will enter into the screen saver. Option: 5...6000 s

**Parameter “operation block”**

This parameter defines whether active block operation for the TFT. Options:

- Active
- Inactive

If selecting “active”, after nobody operates the TFT for a period, if you want to operate it again, you need enter a password. The delay time is set with the parameter “Duration cleaning blockage (in s)”. The password is set with above parameter “Operation password”.

— **Parameter “Duration cleaning blockage (in s)”**

The parameter is only visible if the parameter “operation block” is set to “active”, which is used to set the delay time that the TFT executes block operation. After nobody operates the TFT, and the delay time has passed, if you want to operate it again, you need enter a password. Option: 10...255

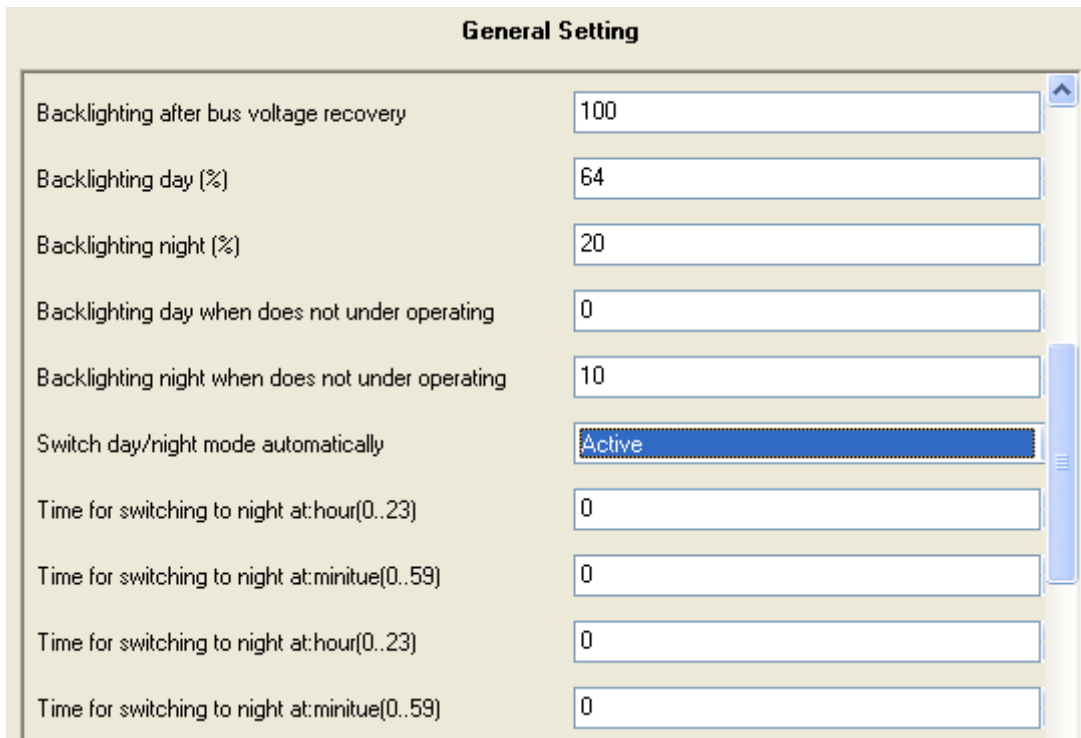

Fig. 5.1 parameter window “General Setting” (2)

#### **Parameter “backlighting after bus voltage recovery”**

This parameter is used to set the backlight brightness of screen after bus voltage recovery or reset. Option: 10...100%

#### **Parameter “backlighting day (%)”**

This parameter is used to set the backlight brightness of screen in the day. Option: 10...100%

#### **Parameter “Backlighting night (%)”**

This parameter is used to set the backlight brightness of screen in the evening. Option: 10...100%

Via object “day/night mode” the backlight brightness can be switched to the defined values in the above two parameters.

Note: after bus voltage recovery or reset, if the object “day/night mode” has not received a telegram value, when the TFT is operated, the backlight is changed from brightness of recovery to brightness of day.

#### **Parameter “backlighting day when does not under operating (%)”**

This parameter defines the backlighting of day when the TFT does not under operating. Option: 0...100%

#### **Parameter “Backlighting night when does not under operating (%)”**

This parameter defines the backlighting of night when the TFT does not under operating. Option: 0...100%

Note: “Do not under operating” mean that the TFT has entered into the screen saver or the delay time that close the backlight has passed.

After bus voltage recovery or reset, if the object “day/night mode” has not received a

telegram value, and the TFT does not under operating, then the backlight is changed to brightness of day under no operating.

#### Parameter “Switch day/night mode automatically”

The parameter defines whether the function that backlight of the TFT switch between the day and night mode automatically is activated. Option:

- Active
- Inactive

If select “Active”, the follow parameters are visible, which are used to set the time that switch between the day and night backlight mode automatically.

##### — Parameter “Time for switching to night at: hour (0...23)/ minute (0...59)”

The parameter defines the time that the backlight switches from day to night mode automatically, e.g. with 18:30, then when the time to 18:30, the backlight of screen switches to night mode automatically.

##### — Parameter “Time for switching to day at: hour (0...23)/ minute (0...59)”

The parameter defines the time that the backlight switches from night to day mode automatically, e.g. with 6:10, then when the time to 6:10, the backlight of screen switches to day mode automatically.

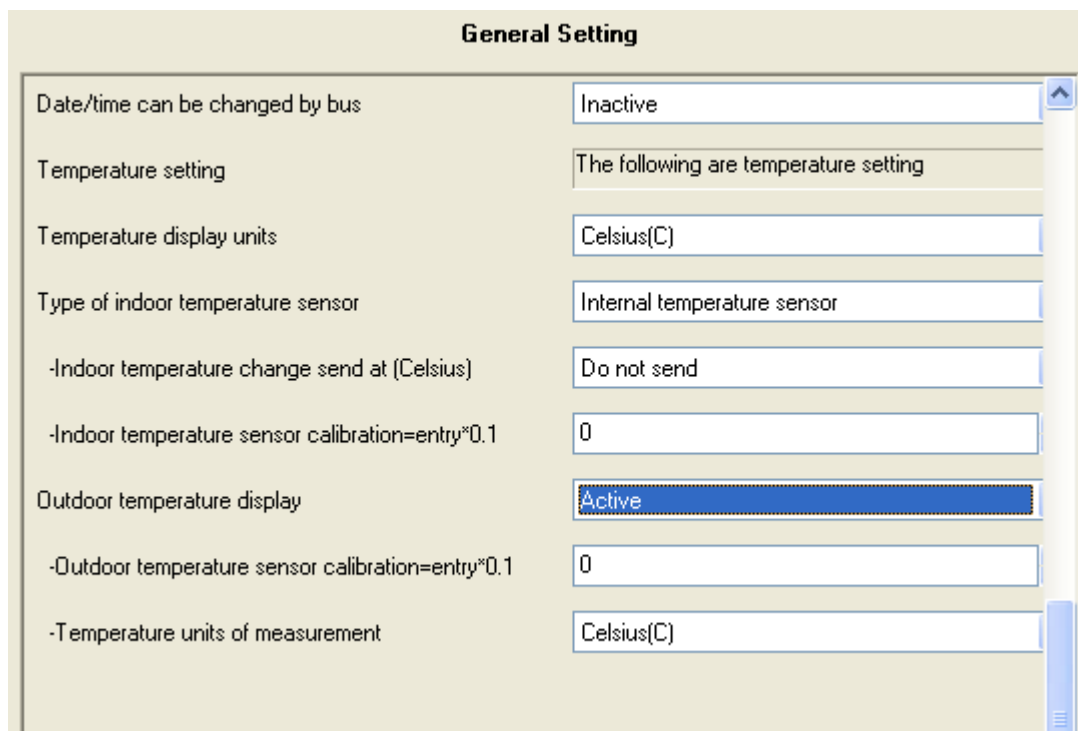

Fig. 5.1 parameter window “General Setting” (3)

#### Parameter “Date/Time can be changed by bus”

The parameter defines whether the date/time in the TFT operation system can be changed by bus. Options:

- Active
- Inactive

If selecting “active”, the objects “date” and “time” will visible, the date and the time can be modified via them.

## **Temperature setting**

The following parameters are used to set temperature display in the TFT operation system.

### **Parameter “Temperature display units”**

Here set temperature display units. Options:

Celsius (C)

Fahrenheit ( F)

### **1. Indoor temperature setting**

#### **Parameter “Type of indoor temperature sensor”**

Here set the type of indoor temperature sensor. Options:

Internal temperature sensor

External temperature sensor

If selecting “Internal temperature sensor”, measure the indoor temperature via the temperature sensor in the TFT device, and the measure value can be sent or read to the bus via the object “Indoor actual temperature” and can be displayed in the TFT operation system.

If selecting “External temperature sensor”, measure the indoor temperature via the external temperature sensor, the TFT receives the measure value via the object “Indoor actual temperature” from the external temperature sensor and displays it.

The internal temperature sensor is built-in the TFT device. The TFT will generate heat during working, this may affect the sensor to measure temperature, and the measure value may inaccurate. If you require a more accurate temperature, you can select to use the External temperature sensor, and it can measure indoor temperature, and send the measure value to the TFT, then the TFT will display the temperature.

#### **— Parameter “Indoor temperature change send at (Celsius)”**

The parameter is visible if the option “Internal temperature sensor” is selected with the parameter “type of indoor temperature sensor”, it is used to set how much the door temperature change, the related object will send the current temperature to the bus. Option:

Do not send

0.5

1

...

5

If selecting “Do not send”, the measure temperature will not be sent to the bus automatically, unless via the object “Indoor actual temperature” read it.

With the setting “3”, when the temperature changes of 3°C, the object “Indoor actual temperature” will send out the current temperature on the bus.

#### **— Parameter “Monitoring time of external sensor (min)”**

The parameter is visible if the option “External temperature sensor” is selected with the parameter “type of indoor temperature sensor”. The parameter is used to define the time that the TFT device monitors the external temperature sensor. If the TFT device does not receive a special telegram from the external temperature sensor during the time, it will judge that the external temperature sensor goes out of order, and start using the internal temperature sensor. The monitoring time will be recounted when the TFT receives a new telegram from the external temperature sensor.

Option: 1...120min

Note: The monitoring time in the TFT should be at least twice as long as the cyclical sending time of the external temperature sensor to avoid missing telegrams.

In the case of selecting the external temperature sensor, after bus voltage recovery or reset, if the TFT has not received a temperature measure value from the external sensor, it will not show the indoor temperature, until received a temperature or the monitor time has passed.

— **Parameter “Indoor temperature sensor calibration = entry\*0.1”**

Here set indoor temperature calibration, i.e. the TFT will correct the temperature that the indoor temperature sensor detects to avoid the measure temperature with the actual temperature is too large error. Option: -128...127

If the correction value is 50, the sensor detects a temperature of 20°C, then the corrected temperature is  $20+50*0.1=25^{\circ}\text{C}$ .

— **Parameter “Temperature units of measurement”**

The parameter is visible if the option “External temperature sensor” is selected with the parameter “type of indoor temperature sensor”. It is used to set the indoor temperature units of measurement. Options:

- Celsius (C)
- Fahrenheit (F)

If selecting the internal temperature sensor, the temperature units of measurement is defined as Celsius (C).

## 2. Outdoor temperature setting

### Parameter “Outdoor temperature display”

The parameter defines whether the outdoor temperature display is active. Options:

- Active
- Inactive

If selecting “Active”, the following parameters will be visible.

— **Parameter “Outdoor temperature sensor calibration = entry\*0.1”**

Here set outdoor temperature calibration, i.e. the TFT will correct the temperature that the outdoor temperature sensor detects to avoid the measure temperature with the actual temperature is too large error. Option: -128...127

If the correction value is 50, the sensor detects a temperature of 20°C, then the corrected

temperature is  $20+50*0.1=25^{\circ}\text{C}$ .

— **Parameter “Temperature units of measurement”**

It is used to set the outdoor temperature units of measurement. Options:

Celsius (C)

Fahrenheit (F)

Note: The indoor temperature sensor may be the temperature sensor inside the TFT device, or other temperature sensor in the TFT outside (other sensors on the bus), but the both are used to measure the indoor temperature, and then the temperature is displayed in the TFT operation system. The outdoor temperature sensor (other sensors on the bus) is used to measure the outdoor temperature, and then the temperature is displayed in the TFT operation system.

The parameter “temperature units of measurement” should be set to the same as setting of the sensor that is used to measure the temperature, or else lead to display error.

After bus voltage recovery or reset, if the TFT has not received a temperature measure value from outdoor temperature sensor, it will not show the outdoor temperature, until received a temperature.

## **5.2. Parameter window “Lighting”**

Parameter window “Lighting” can be shown in fig 5.2. Here can set up to 18 lighting controls, and their parameters are the same for each lighting control, which can be used to set the function of switching or dimming, the dimming way uses absolutely dimming. Take a lighting control as an example, describing their parameter.

Note: In the parameter interface cannot show 18 lighting controls at a time, when the lighting control is not enough, you can active lighting control continually, until up to 18. For example, when you active the second lighting control, the third lighting control will be visible; when you active the third lighting control, the fourth lighting control will also be visible. The following parameter settings “Blind/Shutter”, “Scene”, “Customize” and “Security” are similar.

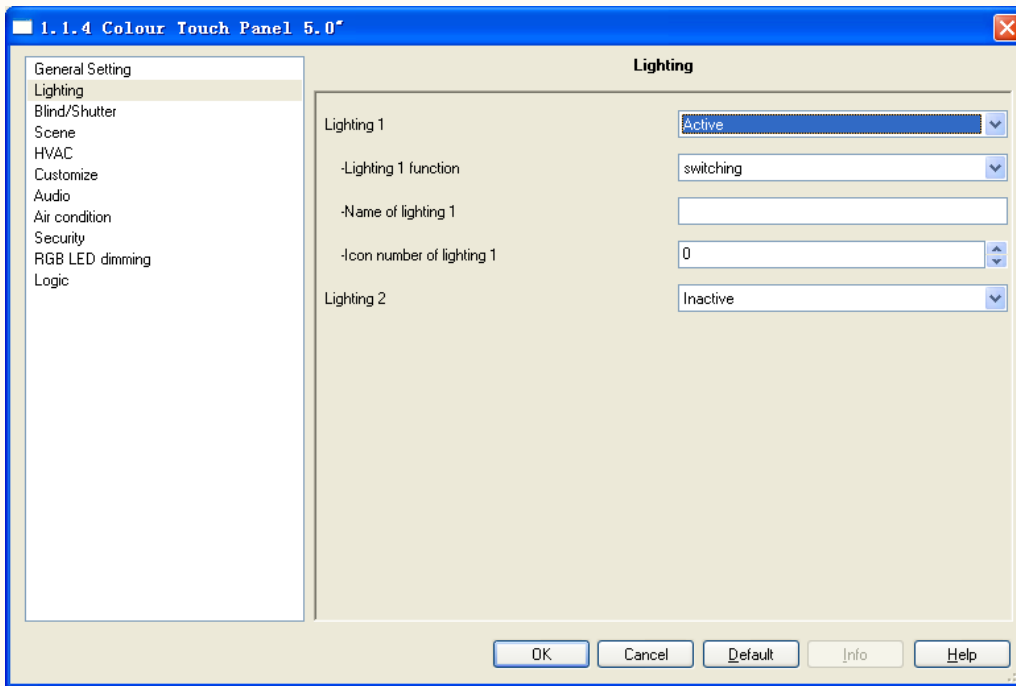

Fig. 5.2 parameter window “Lighting” (switching)

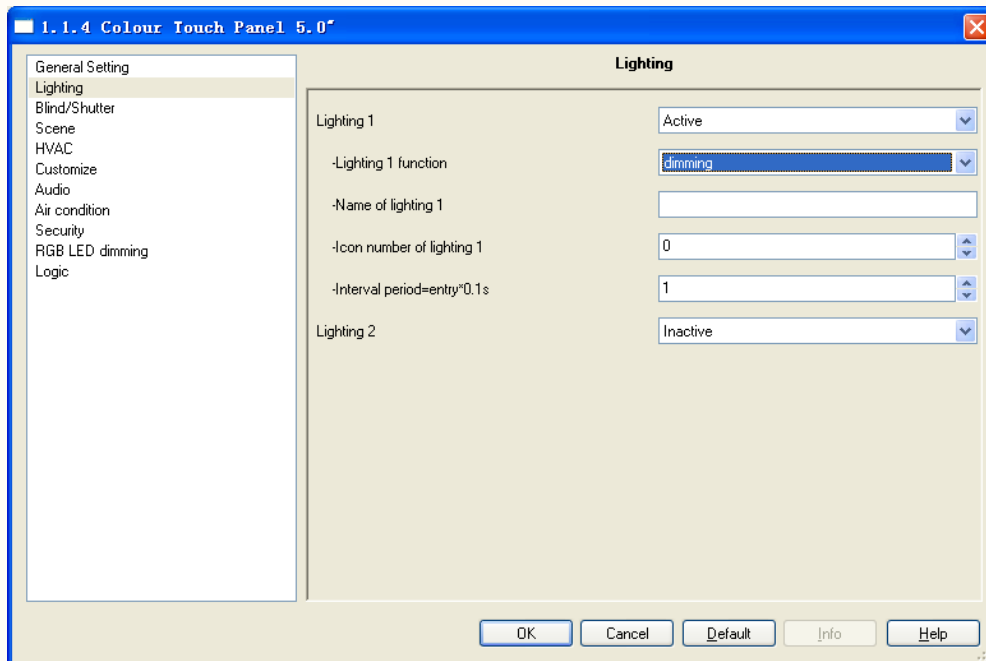

Fig. 5.2 parameter window “Lighting” (dimming)

### Parameter “Lighting x, x=1...18”

This parameter defines whether the lighting x is active. Options:

- Active
- Inactive

If selecting “active”, the following parameters will be visible.

#### — Parameter “Lighting x function”

The parameter is used to set the function of lighting x. Options:

- Switching
- Dimming

If selecting “Switching”, the function can only be used for switching lighting. The objects “switching” and “status” are visible. General, the two objects are used together, e.g. the “switching” is linked to “switch” object of dimmer, the “status” is linked to “switch status” object of dimmer, if the “status” receives a status response from dimmer, the operation icon will updated accordingly in the TFT, when switch on, the icon show color, when switch off, the icon show gray. However, their group addresses can be also set same, and in some case it is quite applicable.

If selecting “Dimming”, the function can be used for switching and dimming lighting. The objects “switching”, “absolute dimming” and “brightness value” are visible. A switch telegram is sent via a short operation. A slider is opened via a long operation, which is used to dim light, and via glide it to send dimming telegram. General, the objects “absolute dimming” and “brightness value” are used together, e.g. the “absolute dimming” is linked to “brightness” object of dimmer, the “brightness value” is linked to “brightness status” object of dimmer. If the “brightness value” receives a non-zero status response from dimmer, the operation icon show color, and then a short operation will trigger a telegram “off”; if a zero status response, the icon show gray, and then a short operation will trigger a telegram “on”.

— **Parameter “Name of light x”**

This parameter is used to set the name that is shown in the TFT operation system for lighting x, at most 10 characters can be input here.

— **Parameter “Icon number of light x”**

This parameter is used to set the icon number that is shown in the TFT operation system for lighting x, which corresponding a relevant image. You can refer to the related document to know the icon number corresponding image. Option: 0...63

Currently workable icon number is 0...7, other is reserved.

— **Parameter “Interval period=entry\*0.1s”**

This parameter is visible if the option “dimming” is selected with the parameter “lighting x function”. It is used to set the interval period that the object “Absolute dimming” sends the dimming telegrams during operation, to avoid bus overloading. Option: 1...10

Note: the time may not be very exact.

### **5.3. Parameter window “Blind/Shutter”**

Parameter window “Blind/Shutter” can be shown in fig. 5.3. Here can set up to 6 blind/shutter controls, and their parameters are the same for each blind/shutter control. There are two functions to be realized: shutter or roller blind. In the case of shutter, a long operation sends a blind up or down travel command, and a short operation sends a slats adjustment command. A blind/shutter control function has three operation buttons in the TFT operation system, the middle button is used to stop blind/shutter travel. Take a blind/shutter control as an example, describing their parameter.



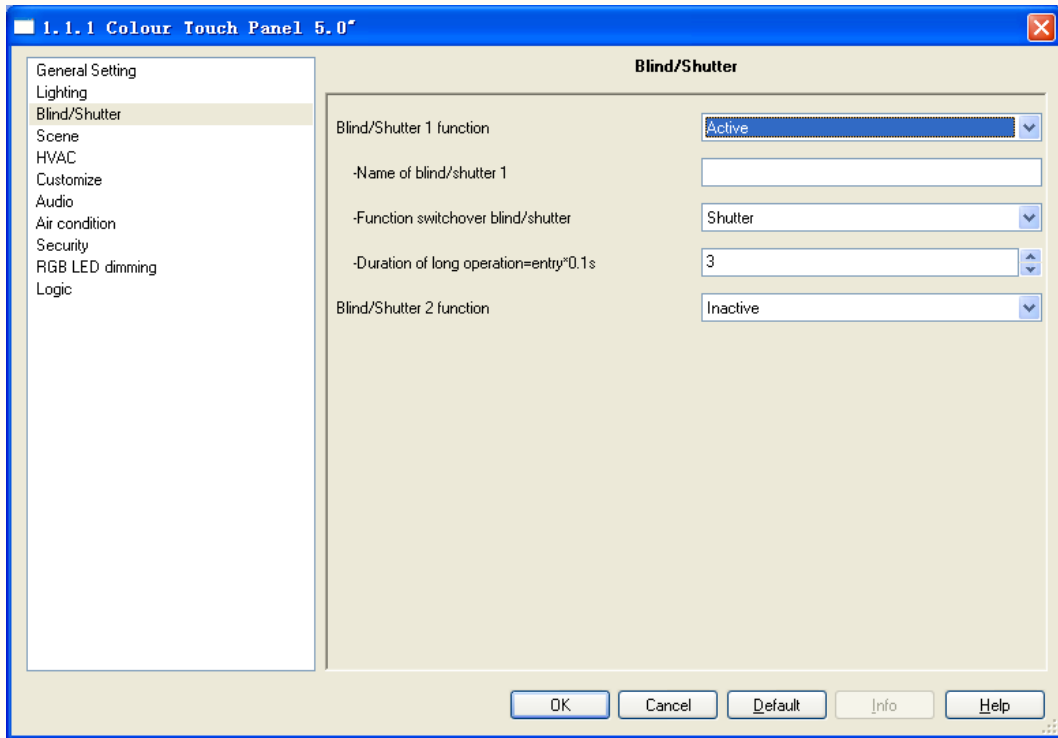

Fig. 5.3 parameter window “Blind/Shutter” (Shutter)

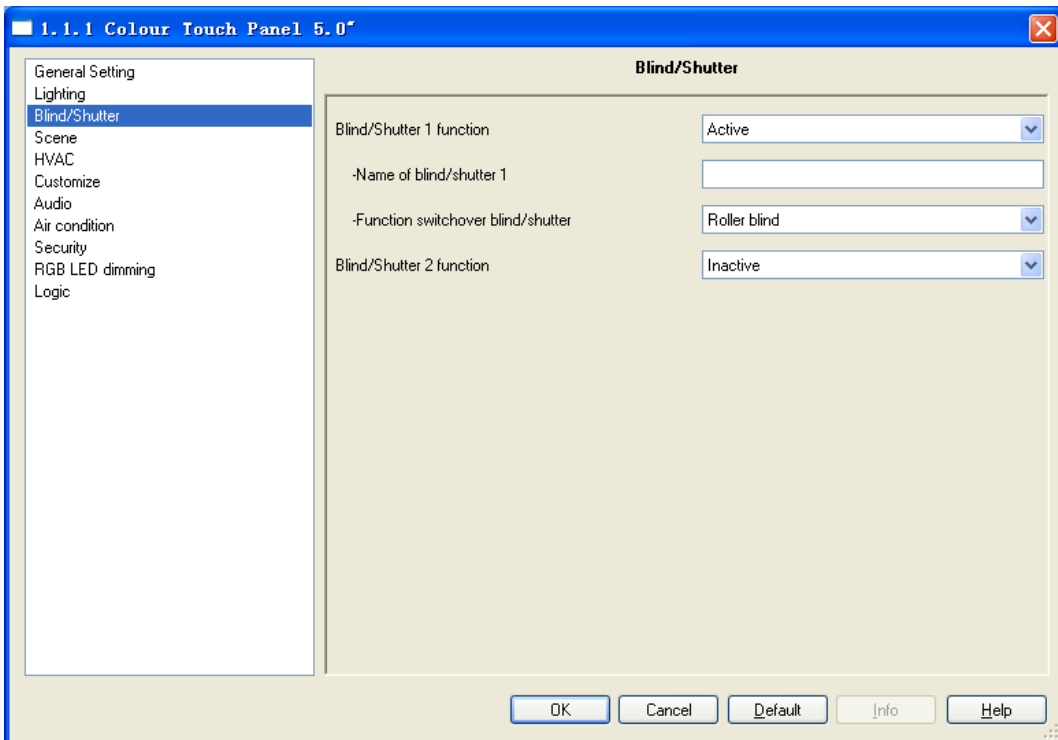

Fig. 5.3 parameter window “Blind/Shutter” (Roller blind)

### Parameter “Blind/Shutter x function, x=1...6”

This parameter defines whether blind/shutter x control function is active. Options:

- Active
- Inactive

If selecting “active”, the following parameters will be visible.

- **Parameter “Name of blind/shutter x”**

This parameter is used to set the name that is shown in the TFT operation system for blind/shutter x, at most 10 characters can be input here.

— **Parameter “Function switchover blind/shutter”**

The parameter is used to define whether a roller blind or shutter is to be driven by an operation of the TFT. Options:

- Shutter
- Roller blind

With the setting “shutter”, a long operation always triggers a blind up/down travel command, and a short operation always triggers a slats adjustment command.

With the setting “Roller blind”, here does not apply slats adjustment, and no need to distinguish long operation and short operation.

— **Parameter “Duration of long operation=entry\*0.1s”**

This parameter is visible if the option “shutter” is selected with the parameter “function switchover blind/shutter”. It is used to define the time which a long operation is recognized. Option: 3...30

#### 5.4. Parameter window “Scene”

Parameter window “Scene” can be shown in fig. 5.4. Here can set up to 18 scene controls, and can activate scene storage functions. A predefined scene number can be recalled via a short operation and stored via a long operation. Their parameters are the same for each scene control. Take a scene control as an example, describing their parameter.

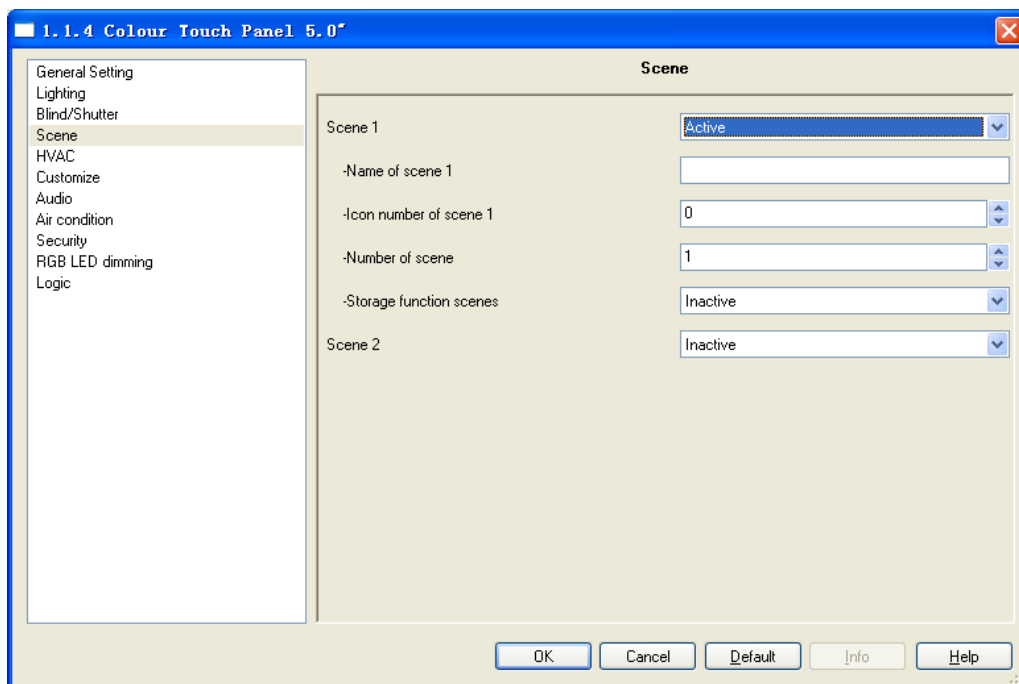

Fig. 5.4 parameter window “Scene”

#### Parameter “Scene x, x=1...18”

This parameter defines whether scene x control function is active. Options:

Active  
Inactive

If selecting “active”, the following parameters will be visible.

— **Parameter “Name of scene x”**

This parameter is used to set the name that is shown in the TFT operation system for scene x, at most 10 characters can be input here.

— **Parameter “Icon number of scene x”**

This parameter is used to set the icon number that is shown in the TFT operation system for scene x. Option: 0...63

Currently workable icon number is 0...23, other is reserved.

— **Parameter “Number of scene ”**

The parameter is used to set an arbitrary scene number from 1 to 64 which can be sent out via the object “number of scene” for an operation of the TFT. Options: 1...64

— **Parameter “Storage function scenes”**

It is used to set whether the scene storage function is enabled. Options:

Inactive  
Active

With the setting “Active”, the following parameter “Duration of long operation=entry\*0.1s” will be visible. The object “Number of scene” can send a telegram of storage scene via a long operation.

— **Parameter “Duration of long operation=entry\*0.1s”**

This parameter will be visible if the option “active” is selected with the parameter “storage function scenes”. It is used to define the time which a long operation is recognized. Option: 3...100

## 5.5. Parameter window “HVAC”

Parameter window “HVAC” can be shown in fig.5.5. The application is mainly used for control room temperature controller, make it turn on or off automatically, and in the case of someone or no one can also make it regulate the indoor temperature automatically according to predefined procedure to a comfortable temperature. Control type: 1bit (on/off), 1byte (continuous), fan coil.

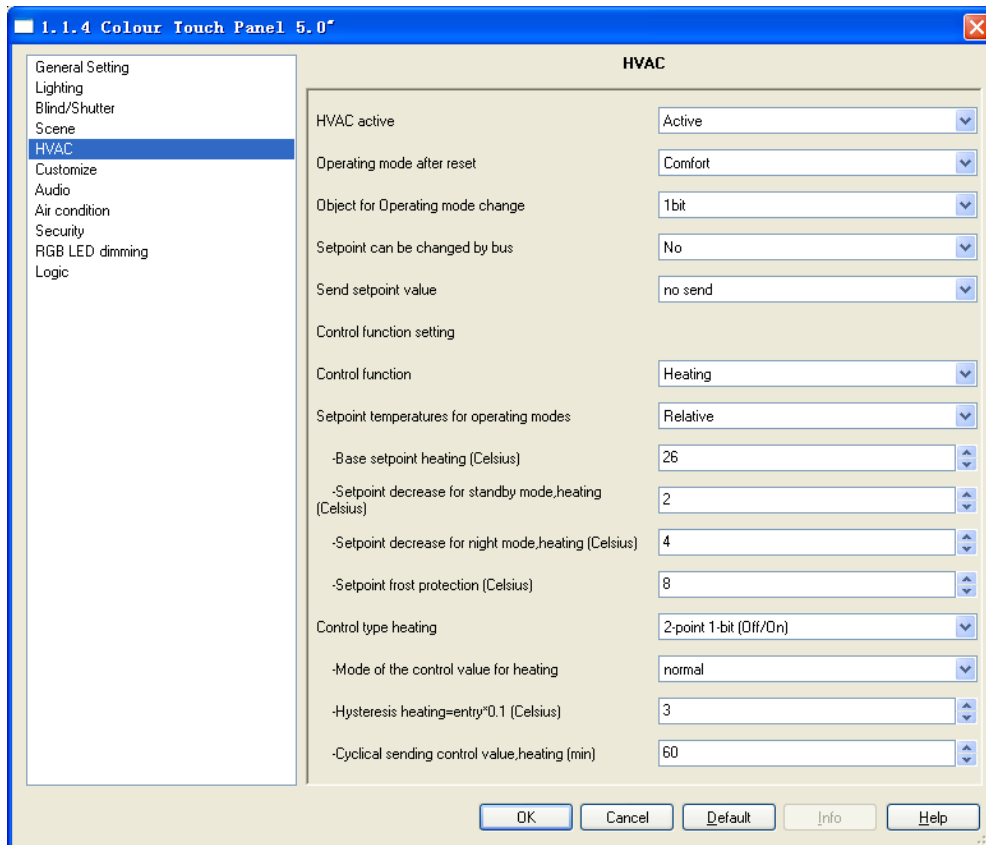

Fig. 5.5 parameter window “HVAC”

### Parameter “HVAC active”

This parameter defines whether HVAC control function is active. Options:

- Active
- Inactive

If selecting “active”, the following parameters will be visible.

### Parameter “Operating mode after reset”

This parameter is used to set the operating mode after bus voltage recovery or reset. Options:

- Comfort
- Standby
- Night
- Frost/heat protection

### Parameter “Object for Operation mode change”

This parameter is used to define the size of the object for the RTC operating. Options:

- 1bit
- 1byte

With the setting “1bit”, the 1-bit objects “Frost/heating protection mode”, “Night operating mode” and “Comfort operating mode” will be visible. Room temperature controllers can be switch to different operating modes via the objects, if the telegrams values of the objects are “0”, the current mode is switched to standby mode.

With the setting “1byte”, the 1-byte object “RTC operation mode” will be visible, and is used for

operation modes switchover. In this case, the object values mean: 1—comfort, 2—standby, 3—night, 4—frost/heat protection.

#### **Parameter “Setpoint can be changed by bus”**

The parameter defines whether the setpoint can be changed via bus. Options:

- No
- Yes

With the setting “Yes”, the setpoint can be changed via the object “Setpoint”.

#### **Parameter “Send setpoint value”**

This parameter is used to set how to send the temperature setpoint value to the bus via the object “Setpoint”. Options:

- No send
- Only after change
- Send cyclically

If “no send” is set, the setpoint value will always be updated but not sent.

With the “Only after change” setting, the setpoint value is only sent if the setpoint value changes.

If “Send cyclically” is set, the setpoint value will be sent cyclically to the bus via the object “setpoint”. If the setpoint value changes, it will be sent immediately and the time of cyclical sending will re-start.

#### **— Parameter “Time of cyclical sending setpoint (min) ”**

This parameter is only visible if the option “Send cyclically” is selected with the above parameter “Send setpoint value”. It is used to set the interval time between two temperature setpoints that are sent cyclically. Option: 1...60

### **Control function setting**

#### **Parameter “Control function”**

This Parameter is used to set control function for room temperature controller. Options:

- Heating
- Cooling
- Heating and cooling

The parameters and objects are different for the different functions. However, the application of heating is similar to that of cooling, also in the parameter and object to be setting. The only difference is that the Heating is used to heat, while the Cooling is used to cool. Both of them is combined to use in the Heating and Cooling function together, the parameters and objects are also similar to other functions except adding a object to switch between heating and cooling. Therefore, the following will explain the parameters using together. The parameters of different control functions are showed in the following figure:

|   |          |
|---|----------|
| Control function                                      | Heating  |
| Setpoint temperatures for operating modes             | Relative |
| -Base setpoint heating (Celsius)                      | 26       |
| -Setpoint decrease for standby mode,heating (Celsius) | 2        |
| -Setpoint decrease for night mode,heating (Celsius)   | 4        |
| -Setpoint frost protection (Celsius)                  | 8        |

Parameter "Heating"

|  |          |
|--|----------|
| Control function                                 | Cooling  |
| Setpoint temperatures for operating modes        | Relative |
| -Base setpoint cooling (Celsius)                 | 21       |
| -Setpoint standby cooling, incremental (Celsius) | 10       |
| -Setpoint night cooling, incremental (Celsius)   | 0        |
| -Setpoint heat protection (Celsius)              | 5        |

Parameter "cooling"

|   |                     |
|---|---------------------|
| Control function                                      | Heating and cooling |
| Operating mode after reset                            | Cooling             |
| Setpoint temperatures for operating modes             | Relative            |
| -Base setpoint heating (Celsius)                      | 26                  |
| -Setpoint decrease for standby mode,heating (Celsius) | 2                   |
| -Setpoint decrease for night mode,heating (Celsius)   | 4                   |
| -Setpoint frost protection (Celsius)                  | 8                   |
| -Base setpoint cooling (Celsius)                      | 21                  |
| -Setpoint standby cooling, incremental (Celsius)      | 10                  |
| -Setpoint night cooling, incremental (Celsius)        | 0                   |
| -Setpoint heat protection (Celsius)                   | 5                   |

Parameter "heating and cooling"

### Parameter "Operation mode after reset"

This parameter will be visible if the option "Heating and cooling" is selected with the parameter "Control function". It is used to set the control function after bus voltage recovery or reset.

Options:

Heating

Cooling

In the case of heating and cooling function, the object "Switchover heating/cooling" can be used for the two functions switchover.

### Parameter "Setpoint temperatures for operating modes"

This parameter defines whether the temperatures setpoint refers to relative setpoint or absolute

setpoint for operating modes. Options:

- Relative
- Absolute

If selecting relative setpoint, mean that a comfort temperature (base setpoint) is defined and other setpoints such as temperature at standby or night refer to this point. For example, the standby temperature 2°C is set lower than the comfort temperature (base setpoint). At a comfort temperature of 21°C, the standby temperature is 19°C. If you raise the comfort temperature to 22°C, the standby temperature automatically changes to 20°C. If the standby temperature is raised from 20°C to 21°C via operating the TFT or other ways, then when the comfort temperature is raised from 22°C to 23°C again, and the standby temperature will also raise to 22°C automatically.

If selecting absolute setpoint, the setting allows you to choose a separate temperature on the room temperature controller for each setpoint; the room temperature controller always refers to this setting in the respective operating mode. For example, the standby temperature is set permanently at 19°C, if you raise the comfort temperature from 21°C to 22°C, the standby temperature does not change.

- **Parameter “Base setpoint heating”/ Parameter “Base setpoint Cooling (Celsius) ”**

This parameter specifies the comfort temperature (base setpoint) for the heating/cooling mode.

Options: 10...40

- **Parameter “Setpoint decrease for standby mode, heating (Celsius) ” / Parameter “Setpoint standby Cooling, incremental (Celsius)”**

These parameters are only visible if the option “relative” is selected with the parameter “setpoint temperatures for operating modes”. The standby setpoint allows you to specify the number of degrees Celsius that the base setpoint is raised or lowered during standby mode for the heating/cooling. For example, here set 3°C for the standby heating setpoint, if the base setpoint is 23°C, the standby setpoint will be 20°C. If here set 3°C for the standby cooling setpoint, if the base setpoint is 23°C, the standby setpoint will be 26°C. Option: 0...15

- **Parameter “Setpoint decrease for night mode, heating (Celsius) ” / Parameter “Setpoint night Cooling, incremental (Celsius)”**

These parameters are only visible if the option “relative” is selected with the parameter “setpoint temperatures for operating modes”. The night setpoint allows you to specify the number of degrees Celsius that the base setpoint is raised or lowered during night mode for the heating/cooling. For example, here set 3°C for the night heating setpoint, if the base setpoint is 23°C, the night setpoint will be 20°C. If here set 3°C for the standby cooling setpoint, if the base setpoint is 23°C, the night setpoint will be 26°C. Option: 0...15

- **Parameter “Setpoint standby heating, absolute (Celsius) ” / Parameter “Setpoint standby cooling, absolute (Celsius)”**

These parameters are only visible if the option “absolute” is selected with the parameter “setpoint temperatures for operating modes”, which are used to specify the individual standby

temperature for the heating/cooling mode. The temperature value specified does not depend on the base setpoint configured for heating/cooling. Option: 10...40

— **Parameter “Setpoint night heating, absolute (Celsius)” / Parameter “Setpoint night cooling, absolute (Celsius)”**

These parameters are only visible if the option “absolute” is selected with the parameter “setpoint temperatures for operating modes”, which are used to specify the individual night temperature for the heating/cooling mode. The temperature value specified does not depend on the base setpoint configured for heating/cooling. Option: 10...40

**Parameter “Setpoint frost protection (Celsius)” / Parameter “Setpoint heat protection (Celsius)”**

These parameters are used to set the temperature for the frost/heating protection. During frost protection mode the current temperature may not be fallen below the temperature. If the current temperature undershoots the configured value, the room temperature controller triggers a control value telegram that cases the relevant heating actuator to heat up the room to prevent damage to the heating system from frost-related cooling, vice versa. Option: 5...40

## Control type setting

### Parameter “Control type heating”/ Parameter “Control type cooling”

This parameter is used to set control types for the heating or cooling function. Different control types are suitable for controlling different temperature controller. Options:

- 2-point 1-bit (Off/On)
- 2-point 1-byte (0/100%)
- PI continuous
- PI PWM (1-bit)
- Fan coil

The parameters and objects to be using are different for these control types, but some of them are similar. Here no distinction to be described to avoid repeat. The parameters of different control types are showed in the following figure:

Note: if the control type does not have a parameter, then it does not have the function of the parameter.



|   |                        |
|---|------------------------|
| Control type heating                          | 2-point 1-bit (Off/On) |
| -Mode of the control value for heating        | normal                 |
| -Hysteresis heating=entry*0.1 (Celsius)       | 3                      |
| -Cyclical sending control value,heating (min) | 60                     |
| Control type cooling                          | 2-point 1-bit (Off/On) |
| -Mode of the control value for cooling        | normal                 |
| -Hysteresis cooling=entry*0.1 (Celsius)       | 3                      |
| -Cyclical sending control value,cooling (min) | 60                     |

2-point 1-bit (Off/On) / 2-point 1-byte (0/100%)

|   |               |
|---|---------------|
| Control type heating                          | PI continuous |
| -PI automatic tuning                          | Inactive      |
| -Proportional Area=entry*0.1                  | 10            |
| -I component cooling (min)                    | 0             |
| -Cyclical sending control value,heating (min) | 60            |
| -max. control value heating                   | 255           |
| -min. control value heating                   | 0             |
| Control type cooling                          | PI continuous |
| -PI automatic tuning                          | Inactive      |
| -Proportional Area=entry*0.1                  | 10            |
| -I component cooling (min)                    | 0             |
| -Cyclical sending control value,cooling (min) | 60            |
| -max. control value cooling                   | 255           |
| -min. control value cooling                   | 0             |

PI continuous

|  |                |
|--|----------------|
| Control type heating                   | PI PWM (1-bit) |
| -Mode of the control value for heating | normal         |
| -PI automatic tuning                   | Inactive       |
| -Proportional Area=entry*0.1           | 10             |
| -I component cooling (min)             | 0              |
| -PWM Period in(min)                    | 1              |
| -max. control value heating            | 255            |
| -min. control value heating            | 0              |
| Control type cooling                   | PI PWM (1-bit) |
| -Mode of the control value for cooling | normal         |
| -PI automatic tuning                   | Inactive       |
| -Proportional Area=entry*0.1           | 10             |
| -I component cooling (min)             | 0              |
| -PWM Period in Min                     | 1              |
| -max. control value cooling            | 255            |
| -min. control value cooling            | 0              |

PI PWM (1-bit)

|   |          |
|---|----------|
| Control type heating                          | Fan coil |
| -PI automatic tuning                          | Inactive |
| -Proportional Area=entry*0.1                  | 10       |
| -I component cooling (min)                    | 0        |
| -Control value output for fan high speed      | 255      |
| -Control value output for fan medium speed    | 150      |
| -Control value output for fan low speed       | 50       |
| -Cyclical sending control value,heating (min) | 60       |
| -max. control value heating                   | 255      |
| -min. control value heating                   | 0        |
| Control type cooling                          | Fan coil |
| -PI automatic tuning                          | Inactive |
| -Proportional Area=entry*0.1                  | 10       |
| -I component cooling (min)                    | 0        |
| -Control value output for fan high speed      | 255      |
| -Control value output for fan medium speed    | 150      |
| -Control value output for fan low speed       | 50       |
| -Cyclical sending control value,cooling (min) | 60       |
| -max. control value cooling                   | 255      |
| -min. control value cooling                   | 0        |

Fan coil

— **Parameter “Mode of the control value for heating/Cooling”**

The parameter can be used to adapt control value to "normal" or "inverse" valves. Options:

Normal

Inverse

If selecting “normal”, the object “Heating/Cooling control value” sends out the control value normally. For example, the object sends out a telegram “on” or “100%” to open the temperature control valves, and sends out a telegram “off” or “0%” to close the valves.

If selecting “inverse”, the object “Heating/Cooling control value” sends out the negated control value. For example, the object sends out a telegram “off” or “0%” to open the temperature control valves, and sends out a telegram “on” or “100%” to close the valves.

Note: if the control type of “...1bit”, the object “Heating/Cooling control value” can only send out the telegrams “on” and “off”; if the control type of “2-point 1byte”, the object can

only send out the telegrams “0%” and “100%”.

— **Parameter “Hysteresis heating/Cooling =entry\*0.1(Celsius) ”**

These parameters are only available if the "2-point control" is set as control type, which are used to set a hysteresis value to ensure that the valve does not constantly switch with each minor under and overshoot when using 2-point control of the actuator. The hysteresis value lies around the setpoint. For example, if the setpoint is 23 °C and the hysteresis is 2°C, the room temperature controller when cooling sends only an "on" signal at 24 °C and an "off" signal at 22 °C. If the setpoint is 20 °C and the hysteresis is 3°C, the room temperature controller when heating sends only an "off" signal at 21.5 °C and an "on" signal at 18.5 °C. Option: 3...255

— **Parameter “Cyclical sending control value, heating/Cooling (min) ”**

The parameters set the time interval which the control value will be send out cyclically on the bus, and also when the control value has still the same value. Option: 1...60

If the control value changes, and will send on the bus immediately, the cyclic time will re-timing.

**Note:** The cyclic time should be correspond to the monitoring time of the heating/cooling actuator. A good setting for the cyclic time is the half of the monitoring time of the heating/cooling actuator.

— **Parameter “PI automatic tuning”**

The parameter defines whether the PI automatic tuning is active. Options:

Inactive

Active

If active, PI parameter values can be taken via the Auto-Tuning function, which have been set within the application program rather than set via the follow parameters.

If inactive, PI parameter values will be set via the follow two parameters.

— **Parameter “Proportional Area=entry\*0.1”**

This parameter is only visible if the parameter “PI automatic tuning” is set to “inactive”, which sets the P (Proportion) parameter value. Option: 10...250

— **Parameter “I component heating/Cooling (min) ”**

This parameter is only visible if the parameter “PI automatic tuning” is set to “inactive”, which sets the I (Integration) parameter value. Option: 0...255

— **Parameter “PWM Period in (min) ”**

The parameter defines the period that the object value is sent out cyclically on the bus for the PI PWM control type. With PWM control, the actuator switches the valve drive depending on the PI control value. Example: For a cyclic time of 10 min. and a PI control value of 60%, the valve drive is switched on for 6 min. and off for 4 min. Option: 1...60

**Note:** if the PI control value is 100% or 0%, i.e. completely open or close, the object value will not be sent cyclically, until the PI control value is change between 1 to 99%.

The PI control values of “PI continuous” and “PI PWM (1bit)” are same, but their control objects are not same, the object of “PI continuous” sends the PI control value (1byte) directly, while the object of “PI PWM (1bit)” sends an “on/off” according to the duty cycle of the PI control value.

— **Parameter “max. control value heating/Cooling ”**

The parameter sets the Max. PI control value that is used to limit output of actuator. If using the TFT to control a using PWM actuator, the parameter is essential. With PWM control, if the control value is very large, the switch-off period for the actuator might not be sufficient to put in motion the connected thermoelectric valve gear, lead to the room temperature controller cannot regulate well the indoor temperature or damage the valve. Option: 0...255

— **Parameter “min. control value heating/Cooling ”**

The parameter sets the Min. PI control value that is used to limit output of actuator. If using the TFT to control a using PWM actuator, the parameter is essential. With PWM control, if the control value is very small, the switch-on period for the actuator might not be sufficient to put in motion the connected thermoelectric valve gear, lead to the room temperature controller cannot regulate well the indoor temperature or damage the valve. Option: 0...255

Note: the max. PI control value must be higher than the min. PI control value.

In the case of PI PWM, if cooling, when the current temperature is higher 2 °C than the setpoint, then ignore P and I values and the min. /max. PI control values, the valve will be fully opened or closed to extreme cool, to make the temperature drop to the setpoint quickly; if heating, it is opposite. In other cases, the on /off time is depended on the duty cycle of the PI control value.

— **Parameter “Control value output for fan high speed ”**

The parameter are only available if the "fan coil" is set as control type, which set the value that the object “fan level” should send out on the bus for the high fan speed. Options: 0...255

— **Parameter “Control value output for fan medium speed”**

The parameter are only available if the "fan coil" is set as control type, which set the value that the object “fan level” should send out on the bus for the medium fan speed. Options: 0...255

— **Parameter “Control value output for fan low speed”**

The parameter are only available if the "fan coil" is set as control type, which set the value that the object “fan level” should send out on the bus for the low fan speed. Options: 0...255

## 5.6. Parameter window “Customize”

Parameter window “Customize” can be shown in fig. 5.6. Here can set up to 18 customize groups, each group has three values of different data type. A group telegrams with the predefined

values are sent for an operation in the TFT system. Their parameters are the same for each group. Take a group as an example, describing their parameter.

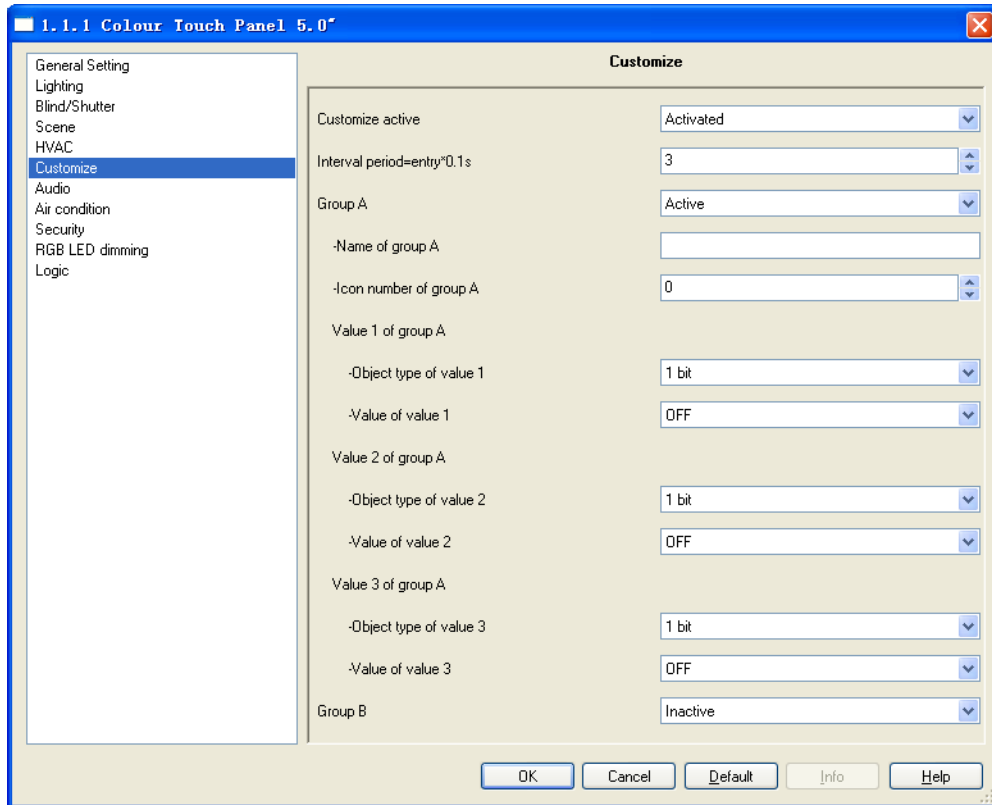

Fig. 5.6 parameter window “Customize”

#### Parameter “Customize active”

This parameter defines whether customize values function is active. Options:

- Active
- Inactive

If selecting “active”, the following parameters will be visible.

#### Parameter “Interval period=entry\*0.1s”

This parameter is used to set the interval period which the object values will be send out on the bus via an operation in the TFT system for a group. Options: 10...50

#### Parameter “Group x, x=A...R”

This parameter defines whether the group x is active. Options:

- Active
- Inactive

If selecting “active”, the following parameters will be visible.

##### — Parameter “Name of group x”

This parameter is used to set the name that is shown in the TFT operation system for group x, at most 10 characters can be input here.

##### — Parameter “Icon number of group x”

This parameter is used to set the icon number that is shown in the TFT operation system for group x. Option: 0...63

Currently workable icon number is 0...23, other is reserved, the icons are same as the scene'.

— **Three values of different data type can be sent for each group, parameter settings is the same for each value in this group, take a value as an example:**

**Value y of group x (y=1...3, x=A...R)**

Value y of group x can be set via the following parameters.

— **Parameter “Object type of value y”**

This parameter is used to the size of the object for sending value y, it specifies the value range. Options:

1bit

1byte 0...100%

1byte 1...255

2byte signed -32768...32767

2byte unsigned 0...65535

2byte float -671088, 64 ...670760, 96

— **Parameter “Value of value y”**

This parameter is used to specify value of value y that is sent for an operation in the TFT system. The value range is dependent on the selected data type.

## **5.7. Parameter window“Audio”**

Parameter window “Audio” can be shown in fig. 5.7. Here set Audio control. When the application is enabled, the objects will be visible for controlling Audio, such as on/off, play/stop, volume control, sound effect, mode etc. The background music module can be controlled directly via the objects.

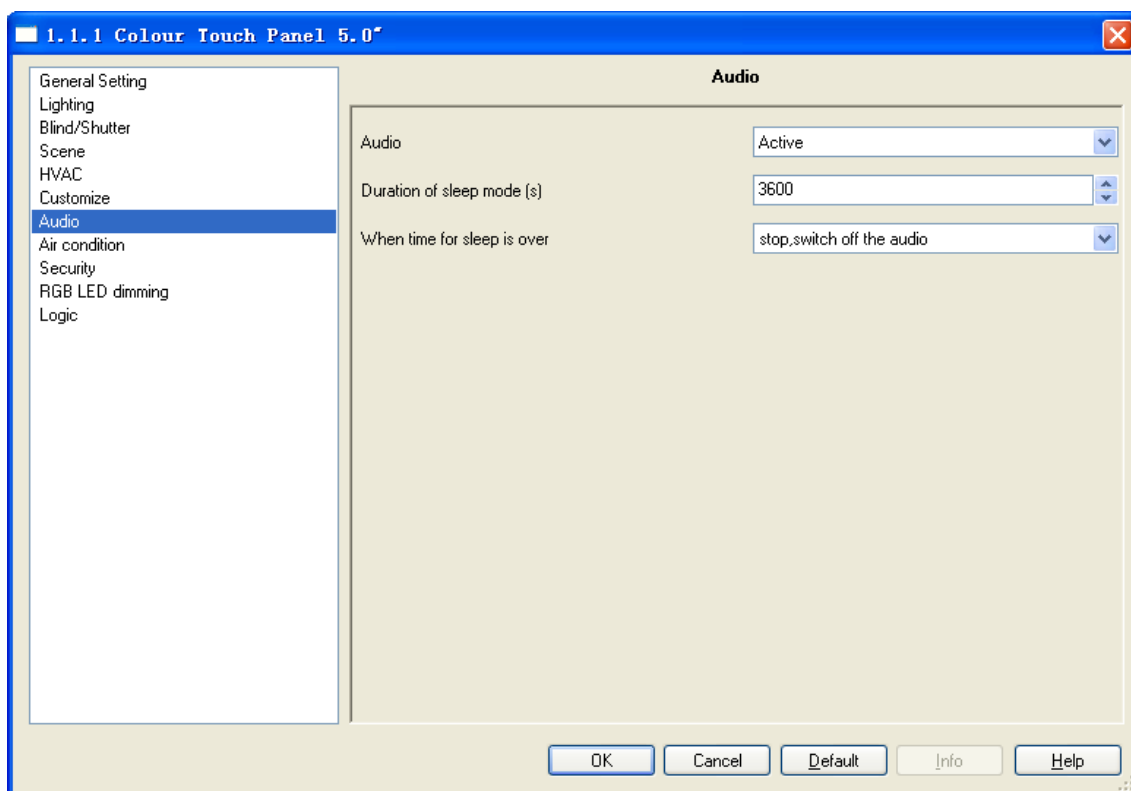

Fig. 5.7 parameter window “Audio”

### Parameter “Audio”

This parameter defines whether the audio control function is active. Options:

- Active
- Inactive

If selecting “active”, the following parameters will be visible.

### Parameter “Duration of sleep mode (s)”

This parameter defines the duration time of sleep mode for the audio. For example, when you want listen music during sleeping, you can enable the sleep mode and set the duration play time here. When the time has passed, stop playing music or turn off the audio. Option: 10...3600

When the object “on/off” sends or receives a telegram “off”, the sleep mode will be interrupted.

The sleep mode as a regular play function, when the duration time has passed, the audio is stopped or turned off.

### Parameter “When time for sleep is over”

This parameter defines whether only stop playing or turn off the audio when the duration time has passed for the sleep mode. Options:

- Stop, switch off the audio
- Stop, but not switch off the audio

If selecting “Stop, switch off the audio”, stop playing music, and turn off the audio.

If selecting “Stop, but not switch off the audio”, stop playing music, but do not turn off the audio.



## 5.8. Parameter window “Air condition”

Parameter window “Air condition” can be shown in fig. 5.8. Here specify functional blocks for controlling air condition. The application offers two object types for output control commands: 1bit and 1byte. In the case of 1bit, the commands are sent out via several 1-bit objects, you can see also the communication object chapter description. In the case of 1byte, the commands are sent out via a 1-byte object, and the object value corresponds to each command is set via the following parameter directly, see also parameter description in this section.

The functions for controlling air condition in the TFT system are similar with the functions on the air-conditioning remote control. The users can learn the functions on the air-conditioning remote control to an IR emitter on the bus via an IR learner, then the application in the TFT should be configured correspond to functions of the IR emitter. Now via the application of the TFT the users will be able to send the control commands to the IR emitter to control the air condition. For example, in the IR emitter configuration a scene 3 (telegram value “2”) correspond to the command for air condition on, so in the TFT the object for air condition on should also be sent out the telegram value “2” .

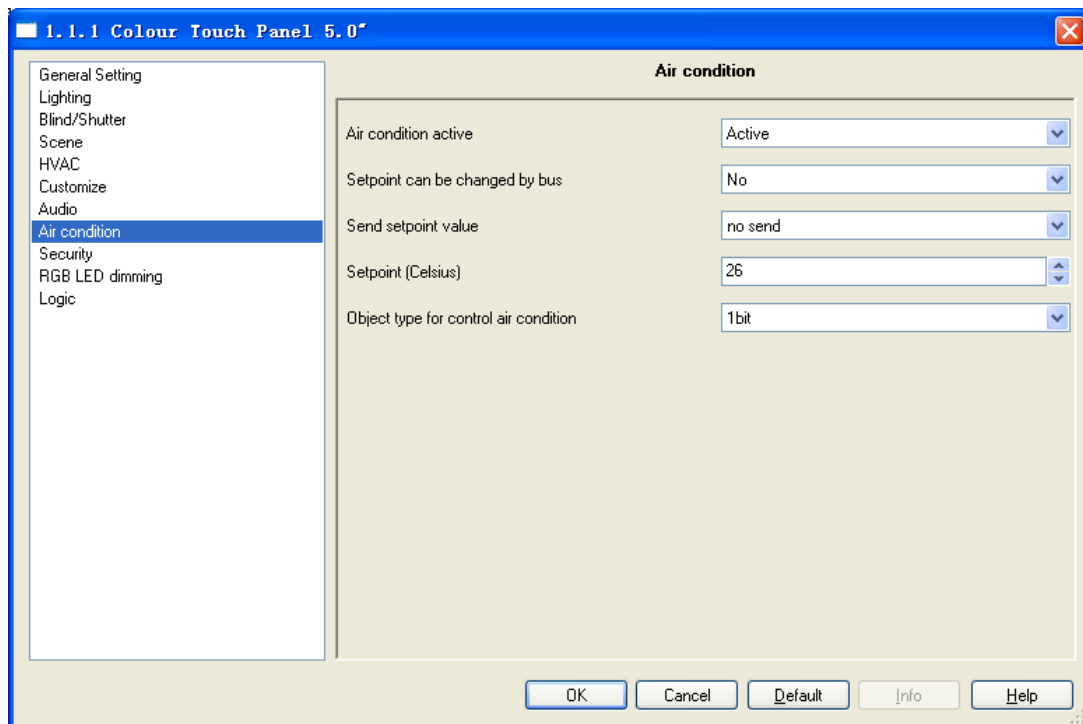

Fig. 5.8 parameter window “Air condition” (1bit)

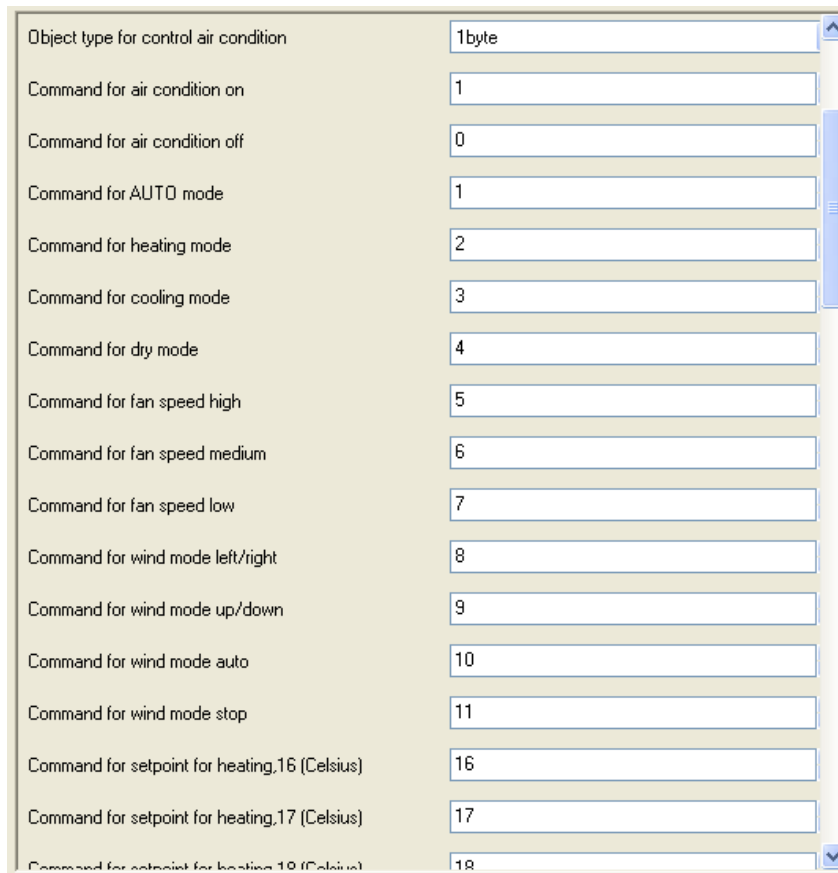

Fig. 5.8 parameter window “Air condition” (1byte)

#### Parameter “Air condition active”

This parameter defines whether air-condition control function is active. Options:

- Active
- Inactive

If selecting “active”, the following parameters will be visible.

#### Parameter “Setpoint can be changed by bus”

The parameter defines whether the setpoint can be changed via bus. Options:

- No
- Yes

With the setting “Yes”, the setpoint can be changed via the object “Setpoint”.

#### Parameter “Send setpoint value”

This parameter is used to set how to send the temperature setpoint value to the bus via the object “Setpoint”. Options:

- No send
- Only after change
- Send cyclically

If “no send” is set, the setpoint value will always be updated but not sent.

With the “Only after change” setting, the setpoint value is only sent if the setpoint value changes.

If “Send cyclically” is set, the setpoint value will be sent cyclically to the bus via the object

“setpoint”. If the setpoint value changes, it will be sent immediately and the time of cyclical sending will re-start.

— **Parameter “Time of cyclical sending setpoint (min) ”**

This parameter is only visible if the option “Send cyclically” is selected with the above parameter “Send setpoint value”. It is used to set the interval time between two temperature setpoint that are sent cyclically. Option: 1...60

**Parameter “Setpoint (Celsius)”**

The parameter defines the default temperature setpoint value for the TFT system after bus voltage recovery or reset, and it can be changed via the bus. Options: 16...31

Note: there can be set 32 in the database, but the value is invalid and handled as 31.

**Parameter “Object type for control air condition”**

The parameter is used to define the size of the objects for control air condition. Option:

1bit

1byte

With the “1bit” setting, the commands for control air condition are sent out via 1-bit objects. See also the communication object chapter description about air condition.

With the “1byte” setting, the commands for control air condition are sent out via a 1-byte object “IR command number”. The object value corresponds to each command is set via the following parameters.

— **Parameter “Command for air condition on”**

The parameter defines the value that the object “IR command number” sends out for air condition on. Option: 0...255

— **Parameter “Command for air condition off”**

The parameter defines the value that the object “IR command number” sends out for air condition off. Option: 0...255

— **Parameter “Command for AUTO mode”**

The parameter defines the value that the object “IR command number” sends out for AUTO mode. Option: 0...255

— **Parameter “Command for heating mode”**

The parameter defines the value that the object “IR command number” sends out for heating mode. Option: 0...255

— **Parameter “Command for cooling mode”**

The parameter defines the value that the object “IR command number” sends out for cooling mode. Option: 0...255

— **Parameter “Command for dry mode”**

The parameter defines the value that the object “IR command number” sends out for dry mode. Option: 0...255

— **Parameter “Command for fan speed high”**

The parameter defines the value that the object “IR command number” sends out for air volume high. Option: 0...255

— **Parameter “Command for fan speed medium”**

The parameter defines the value that the object “IR command number” sends out for air volume medium. Option: 0...255

— **Parameter “Command for fan speed low”**

The parameter defines the value that the object “IR command number” sends out for air volume low. Option: 0...255

— **Parameter “Command for wind mode left/right”**

The parameter defines the value that the object “IR command number” sends out for wind mode left/right. Option: 0...255

— **Parameter “Command for wind mode up/down”**

The parameter defines the value that the object “IR command number” sends out for wind mode up/down. Option: 0...255

— **Parameter “Command for wind mode auto”**

The parameter defines the value that the object “IR command number” sends out for wind mode auto. Option: 0...255

— **Parameter “Command for wind mode stop”**

The parameter defines the value that the object “IR command number” sends out for wind mode stop. Option: 0...255

— **Parameter “Command for setpoint for heating/cooling, x (x=16...31) (Celsius)”**

The parameter defines the value that the object “IR command number” sends out for temperature setpoint x for heating/cooling. Option: 0...255

## **5.9. Parameter window “Security”**

Parameter window “Security” can be shown in fig.5.9. With the application, homeowners can execute a arming when leave home. Such as turn on warning system, reporting of open or broken windows and doors, burglary, smoke emission etc. In the evening prevent deterrence of potential break-ins by switching on the entire home lighting system. Homeowners can execute a disarming when back home by enter into a disarming password and then send a disarming telegram. The application provides up to 6 security settings. The disarming password is set with the parameter window “general setting” (fig. 5.1).

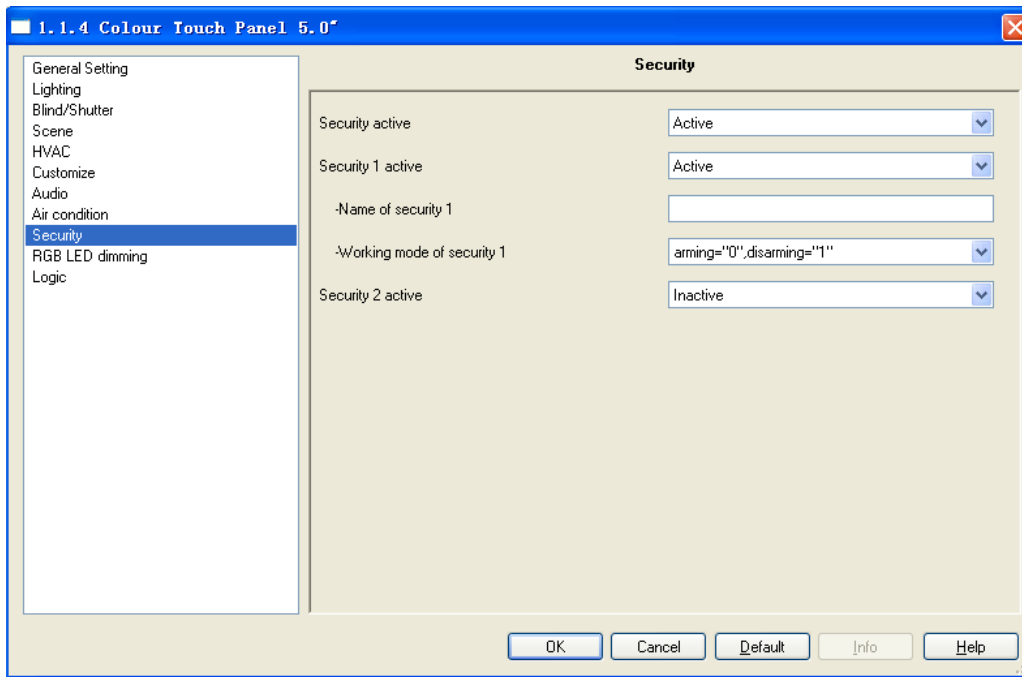

Fig. 5.9 parameter window “Security”

### Parameter “Security active”

This parameter defines whether security function is active. Options:

- Active
- Inactive

If selecting “active”, the following parameter will be visible.

### Parameter “Security x (1...6) active”

This parameter defines whether security function x is active. Options:

- Active
- Inactive

If selecting “active”, the following two parameters will be visible.

#### — Parameter “Name of security x (1...6)”

This parameter is used to set the name that is shown in the TFT operation system for security x, at most 10 characters can be input here.

#### — Parameter “Working mode of security x (1...6)”

This parameter is used to define the working mode of security x. Options:

- Arming= “0”, disarming= “1”
- Arming= “1”, disarming= “0”

If selecting “Arming= ‘0’, disarming= ‘1’ ”, when the object “disarming/arming” sends a telegram “0”, a arming will be executed; When the object sends a telegram “1”, a disarming will be executed.

If selecting “Arming= ‘1’, disarming= ‘0’ ”, when the object “disarming/arming” sends a telegram “1”, a arming will be executed; When the object sends a telegram “0”, a disarming will be executed.

## 5.10. Parameter window“RGB LED dimming”

Parameter window “RGB LED dimming” can be shown in fig. 5.10. Here set RGB LED dimming. When the function is activated, the dimming objects will be visible. R (red), G (green) and B (blue) three-channel colour have their own corresponding object. Via their own object can make the three colour change, as well as superposition and change the three colours can get a variety of colour. Therefore, we can regulate optionally landscape lamp, lighting or other RGB LED to one of ourselves favorite atmosphere through the function.

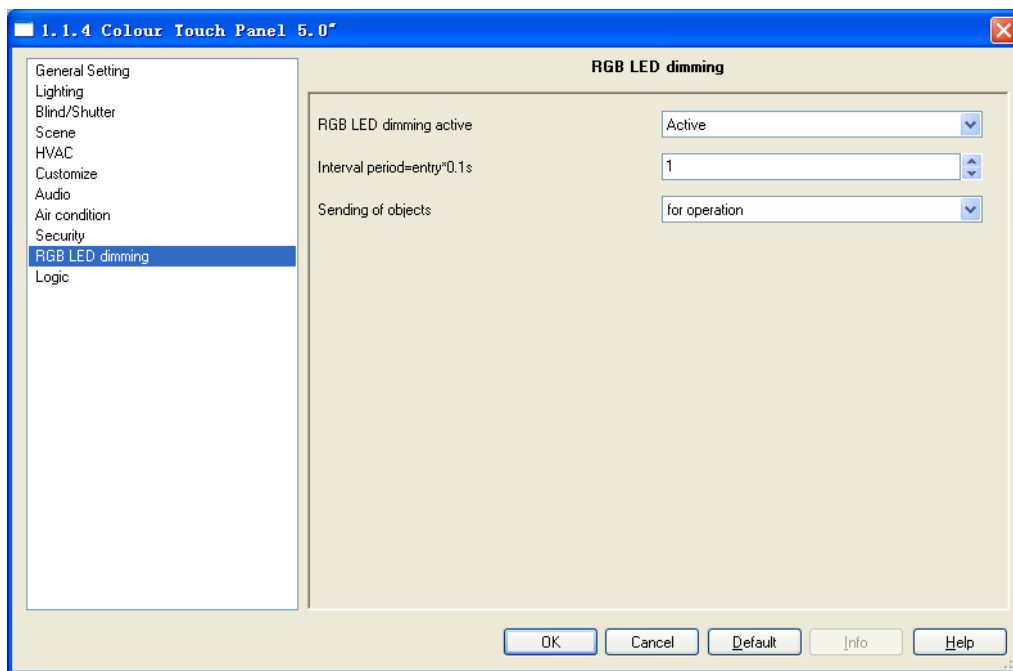

Fig. 5.10 parameter window “RGB LED dimming”

### Parameter “RGB LED dimming active”

This parameter defines whether RGB LED dimming function is active. Options:

- Active
- Inactive

If selecting “active”, the following parameter will be visible.

#### — Parameter “Interval period=entry\*0.1s”

This parameter is used to set the interval period which each group object (including R, G and B dimming objects) sends out their values on the bus. Options: 1...10

Note: the parameter is mainly used to limit the telegrams that are sent for RGB dimming, it may not be very exact.

#### — Parameter “Sending of objects”

This parameter is used to specify whether values of all dimming objects for each operation are sent out or only if values of the objects have changed since the last sending out. Option:

- For operation
- For change of value

## 5.11. Parameter window“Logic”

Parameter window “Logic” can be shown in fig. 5.11. Here can set up to 5 logic operation functions. Each logic function has two input logic values that are received via the objects “input1” and “input2”. Logic value of Input1 makes “AND”, “OR” or “XOR” operation with logic value of input2, and then the operation result is sent to the bus via the object “output”. The function will re-operate when receiving a new object value as the final output. The operation result can be set delay sending via a parameter.

Their parameters are the same for each logic operation function. Take a logic operation as an example, describing their parameter.

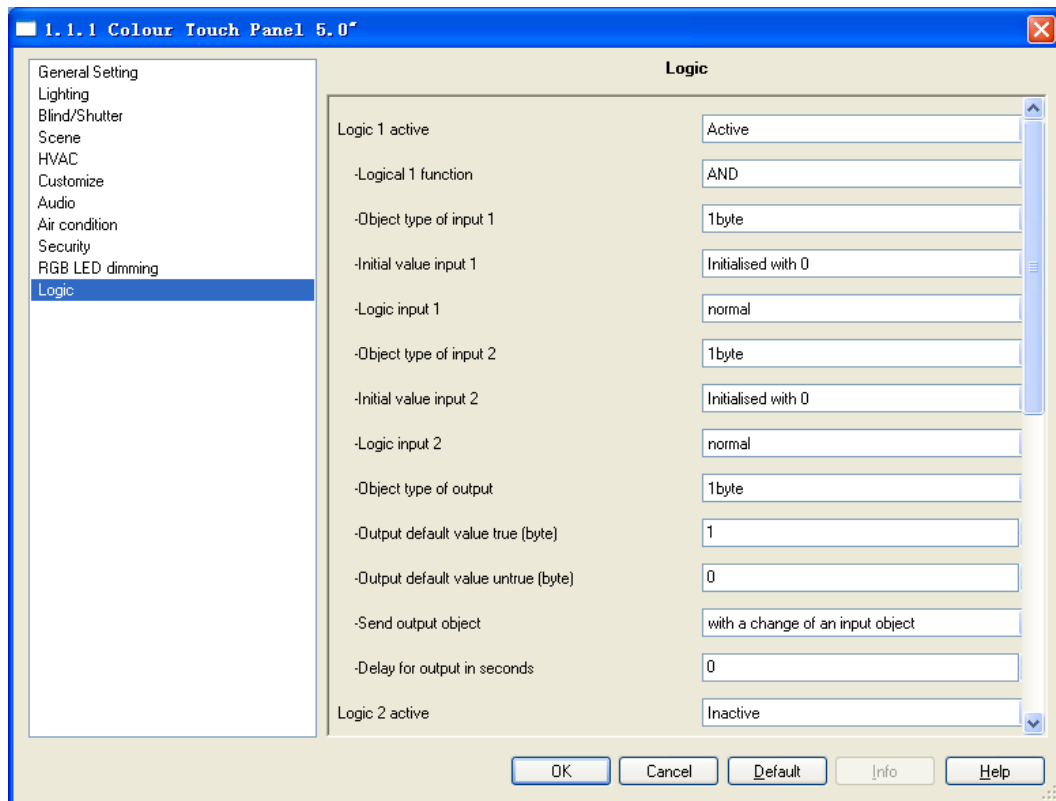

Fig. 5.11 parameter window “Logic”

### Parameter “Logic x active (x=1...5)”

This parameter defines whether logic function x is active. Options:

- Active
- Inactive

If selecting “active”, the following parameter will be visible.

### Parameter “Logic x function”

This parameter is used to set the logical relationship of the logic operation, providing 3 standard logic operations. Options:

AND  
OR  
XOR

#### **Parameter “Object type of input 1/2”**

The parameter is used to define the size of the input objects “input1/2” for input logic values.

Options:

1byte  
1bit

With the “1byte” setting, if the object value is greater than 0, it is true.

#### **Parameter “Initial value input 1/2”**

This parameter defines the initial logic value of the object “input1/2” after bus voltage recovery or reset. Options:

Initialized with 0  
Initialized with 1

#### **Parameter “logic input 1/2”**

This parameter defines whether negate the logic value of the object “input1/2”. Options:

Normal  
Inverse

If selecting “normal”, the logic value of the object “input1/2” Participate in operation directly.

If selecting “inverse”, the logic value of the object “input1/2” is negated, and then Participate in operation.

Note: the initialized value is not inversed.

#### **Parameter “Object type of output”**

The parameter is used to define the size of the output objects “output” for output logic operation result. Options:

1byte  
1bit

#### **Parameter “Output default value true (type)”**

This parameter is used to define the value that the object “output” should be output if the logic operation result is true.

#### **Parameter “Output default value untrue (byte)”**

This parameter is used to define the value that the object “output” should be output if the logic operation result is untrue.

#### **Parameter “Send output object”**

This parameter is used to set how to send the operation result to the bus via the object “output”.

Options:

With a change of an input object  
With a change of output object  
Always

With the “With a change of an input object” setting, if value of an input object is changed, the



output object will send the operation result to the bus.

With the “With a change of output object” setting, if value of the output object is changed, the output object will send the operation result to the bus.

With the “Always” setting, when each time the input objects receive a new input value, the output object always will send the operation result to the bus.

### Parameter “Delay for output in seconds”

The parameter is used to set the delay time for the output object sending result. Options: 0...65535

## 6. Description of communication object

The communication object is the medium to communicate other device on the bus, namely only the communication object can communicate with the bus. Introduce the communication objects of each function in the following.

### 6.1. Communication object “General Setting”

Note: “C” in “Flag” column in the below table means enable the communication function of the object; “W” means value of object can be written from the bus; “R” means the value of the object can be read by the other devices; “T” means the object has the transmission function; “U” means the value of the object can be updated.

| Number | Name    | Object Function           | Description | Group Addresses | Length | C | R | W | T | U | Data Type                         | Priority |
|--------|---------|---------------------------|-------------|-----------------|--------|---|---|---|---|---|-----------------------------------|----------|
| 0      | General | Day/Night mode            |             |                 | 1 bit  | C | - | W | - | - | 1 bit DPT_Switch                  | Low      |
| 1      | General | Time                      |             |                 | 3 Byte | C | - | W | - | - | Time DPT_TimeOfDay                | Low      |
| 2      | General | Date                      |             |                 | 3 Byte | C | - | W | - | - | Date DPT_Date                     | Low      |
| 3      | General | Indoor actual temperature |             |                 | 2 Byte | C | - | W | - | - | 2 byte float value DPT_Value_Temp | Low      |
| 4      | General | Outdoor temperature input |             |                 | 2 Byte | C | - | W | - | - | 2 byte float value DPT_Value_Temp | Low      |

Fig. 6.1 communication object “General Setting”

| No.  | Object Function | name    | Data type | Flags |
|--|-----------------|---------|-----------|-------|
| 0  | Day/Night mode  | General | 1bit      | C,W   |
| <p>If a telegram with the value “1” is received at this communication object, the TFT backlight is switched to day mode. If a telegram with the value “0” is received at this communication object, the TFT backlight is switched to night mode.</p> <p>Telegram value:</p> <p>1—day mode<br/>0—night mode</p> |                 |         |           |       |
| 1  | Time            | General | 3Byte     | C,W   |
| <p>The communication object is used to modify the show time in the TFT system via receiving a telegram with time.</p> <p>Telegram code 3 byte:</p>   |                 |         |           |       |

| 3MSB   |                           |   | 2    |   |   |   |         |   | 1LSB |   |         |   |       |   |   |   |   |   |         |      |   |   |   |   |   |   |   |
|--|---------------------------|---|------|---|---|---|---------|---|------|---|---------|---|-------|---|---|---|---|---|---------|------|---|---|---|---|---|---|---|
| Day  |                           |   | Hour |   |   |   |         |   | 0    | 0 | Minutes |   |       |   |   |   | 0 | 0 | Seconds |      |   |   |   |   |   |   |   |
| N  | N                         | N | U    | U | U | U | U       | U | r    | r | U       | U | U     | U | U | U | U | r | r       | U    | U | U | U | U | U | U | U |
| Day — 0...7, 1=Monday, ..., 7=Sunday, 0=no day   |                           |   |      |   |   |   |         |   |      |   |         |   |       |   |   |   |   |   |         |      |   |   |   |   |   |   |   |
| Hour — 0...23  |                           |   |      |   |   |   |         |   |      |   |         |   |       |   |   |   |   |   |         |      |   |   |   |   |   |   |   |
| Minutes — 0...59   |                           |   |      |   |   |   |         |   |      |   |         |   |       |   |   |   |   |   |         |      |   |   |   |   |   |   |   |
| Seconds — 0...59   |                           |   |      |   |   |   |         |   |      |   |         |   |       |   |   |   |   |   |         |      |   |   |   |   |   |   |   |
| 2  | Date                      |   |      |   |   |   | General |   |      |   |         |   | 3Byte |   |   |   |   |   | C,W     |      |   |   |   |   |   |   |   |
| The communication object is used to modify the show date in the TFT system via receiving a telegram with date.   |                           |   |      |   |   |   |         |   |      |   |         |   |       |   |   |   |   |   |         |      |   |   |   |   |   |   |   |
| Telegram code 3 byte:  |                           |   |      |   |   |   |         |   |      |   |         |   |       |   |   |   |   |   |         |      |   |   |   |   |   |   |   |
| 3MSB   |                           |   | 2    |   |   |   |         |   | 1LSB |   |         |   |       |   |   |   |   |   |         |      |   |   |   |   |   |   |   |
| 0  | 0                         | 0 | Day  |   |   |   |         |   | 0    | 0 | 0       | 0 | Month |   |   |   |   |   | 0       | Year |   |   |   |   |   |   |   |
| r  | r                         | r | U    | U | U | U | U       | U | r    | r | r       | r | U     | U | U | U | U | U | r       | U    | U | U | U | U | U | U | U |
| Day — 1...31, Day of month   |                           |   |      |   |   |   |         |   |      |   |         |   |       |   |   |   |   |   |         |      |   |   |   |   |   |   |   |
| Month — 1...12   |                           |   |      |   |   |   |         |   |      |   |         |   |       |   |   |   |   |   |         |      |   |   |   |   |   |   |   |
| Year — 0...99  |                           |   |      |   |   |   |         |   |      |   |         |   |       |   |   |   |   |   |         |      |   |   |   |   |   |   |   |
| 3  | Indoor actual temperature |   |      |   |   |   | General |   |      |   |         |   | 2Byte |   |   |   |   |   | C,R,T   |      |   |   |   |   |   |   |   |
| This communication object will be visible with “Internal temperature sensor” in the parameter “type of indoor temperature sensor”, which is used to read the measure temperature, or send it to the bus according to the parameter setting.                    |                           |   |      |   |   |   |         |   |      |   |         |   |       |   |   |   |   |   |         |      |   |   |   |   |   |   |   |
| 3  | Indoor actual temperature |   |      |   |   |   | General |   |      |   |         |   | 2Byte |   |   |   |   |   | C,W     |      |   |   |   |   |   |   |   |
| This communication object will be visible with “external temperature sensor” in the parameter “type of indoor temperature sensor”, which is used to receive a telegram with the measure temperature from other external temperature sensor sending on the bus. |                           |   |      |   |   |   |         |   |      |   |         |   |       |   |   |   |   |   |         |      |   |   |   |   |   |   |   |
| 4  | Outdoor temperature input |   |      |   |   |   | General |   |      |   |         |   | 2Byte |   |   |   |   |   | C,W     |      |   |   |   |   |   |   |   |
| This communication object will be visible with “active” in the parameter “outdoor temperature display”, which is used to receive a telegram with the measure temperature from other outdoor temperature sensor sending on the bus.                             |                           |   |      |   |   |   |         |   |      |   |         |   |       |   |   |   |   |   |         |      |   |   |   |   |   |   |   |

Table 6.1 communication object table “General Setting”

## 6.2. Communication object “Lighting”

| Number | Name       | Object Function | Description | Group Addresses | Length | C | R | W | T | U | Data Type        | Priority |
|--------|------------|-----------------|-------------|-----------------|--------|---|---|---|---|---|------------------|----------|
| 6      | Lighting 1 | Status          |             |                 | 1 bit  | C | - | W | - | - | 1 bit DPT_Switch | Low      |
| 5      | Lighting 1 | Switching       |             |                 | 1 bit  | C | - | - | T | - | 1 bit DPT_Switch | Low      |

Fig. 6.2 communication object “Lighting” (switching)

|   |            |                  |  |  |        |   |   |   |   |   |                       |     |
|---|------------|------------------|--|--|--------|---|---|---|---|---|-----------------------|-----|
| 6 | Lighting 1 | Brightness value |  |  | 1 Byte | C | - | W | - | - | 8 bit unsigned val... | Low |
| 7 | Lighting 1 | Absolute dimming |  |  | 1 Byte | C | - | - | T | - | 8 bit unsigned val... | Low |

Fig. 6.2 communication object “Lighting” (dimming)

| No.   | Object function  | Name       | Data type | Flags |
|---|------------------|------------|-----------|-------|
| 5   | Switching        | Lighting x | 1bit      | C, T  |
| <p>The communication object is used to send out an ON telegram or an OFF telegram, to turn on or off lighting.</p> <p>Telegram value:</p> <p>1—ON</p> <p>0—OFF</p>                              |                  |            |           |       |
| 6   | Status           | Lighting x | 1bit      | C,W   |
| <p>The communication object is used to receive a telegram with on/off status response from dimmer or other bus device, and in the TFT system display the current status via graphic button.</p> |                  |            |           |       |
| 6   | Brightness value | Lighting x | 1Byte     | C,W   |
| <p>The communication object is used to receive a telegram with lighting brightness status response from dimmer or other bus device.</p>   |                  |            |           |       |
| 7   | Absolute dimming | Lighting x | 1Byte     | C, T  |
| <p>The communication object is used to send out a telegram with the brightness value to the bus. Telegram value: 0...100%</p>   |                  |            |           |       |

Table 6.2 communication object table “Lighting”

### 6.3. Communication object “Blind/Shutter”

| Number | Name            | Object Function | Description | Group Addresses | Length | C | R | W | T | U | Data Type        | Priority |
|--------|-----------------|-----------------|-------------|-----------------|--------|---|---|---|---|---|------------------|----------|
| 60     | Blind/Shutter 1 | Adjust          |             |                 | 1 bit  | C | - | - | T | - |                  | Low      |
| 59     | Blind/Shutter 1 | Travel          |             |                 | 1 bit  | C | - | - | T | - | 1 bit DPT_UpDown | Low      |

Fig. 6.3 communication object “Blind/Shutter” (Shutter)

| Number | Name            | Object Function | Description | Group Addresses | Length | C | R | W | T | U | Data Type        | Priority |
|--------|-----------------|-----------------|-------------|-----------------|--------|---|---|---|---|---|------------------|----------|
| 60     | Blind/Shutter 1 | Stop            |             |                 | 1 bit  | C | - | - | T | - |                  | Low      |
| 59     | Blind/Shutter 1 | Travel          |             |                 | 1 bit  | C | - | - | T | - | 1 bit DPT_UpDown | Low      |

Fig. 6.3 communication object “Blind/Shutter”(Roll Blind)

| No.   | Object function | name            | Data type | Flags |
|---|-----------------|-----------------|-----------|-------|
| 59  | Travel          | Blind/Shutter x | 1bit      | C,T   |
| <p>The communication object is used to send out a telegram for the blind or shutter UP/DOWN movement.</p> <p>Telegram value:</p> <p>1—DOWN</p> <p>0—UP</p>  |                 |                 |           |       |
| 60  | Adjust          | Blind/Shutter x | 1bit      | C,T   |
| <p>This communication object will be visible with “shutter” in the parameter “function switchover blind/shutter”, which is used to send out a telegram for lamella UP/DOWN adjustment on the bus via a long operation, or send out a telegram for stop movement.</p> <p>Telegram value:</p> <p>1—lamella Down/Stop</p> <p>0—lamella UP/Stop</p> |                 |                 |           |       |
| 60  | Stop            | Blind/Shutter x | 1bit      | C,T   |
| <p>The communication object will be visible with “roller blind” in the parameter “function switchover blind/shutter”, which is used to send out a telegram for stop movement roller blind on the bus.</p> <p>Telegram value: 1/0—Stop</p>   |                 |                 |           |       |

Table 6.3 communication object table “Blind/Shutter”

## 6.4. Communication object “Scene”

| Number | Name    | Object Function | Description | Group Addresses | Length | C | R | W | T | U | Data Type | Priority |
|--------|---------|-----------------|-------------|-----------------|--------|---|---|---|---|---|-----------|----------|
| 71     | Scene 1 | Number of scene |             |                 | 1 Byte | C | - | - | T | - |           | Low      |

Fig. 6.4 communication object “Scene”

| No.   | Object function | name    | Data type | Flags |
|---|-----------------|---------|-----------|-------|
| 71  | Number of scene | Scene x | 1byte     | C,T   |
| <p>The communication object is used to send out a scene number and the information as to whether a scene should be recalled or the current scene should be stored. The number of scene is set in the parameter —Number of scene.</p> <p>Telegram code 8 bit: FXNNNNNN</p> <p>F: 0—Scene is recalled<br/>1—Scene is stored</p> <p>X: Not used</p> <p>NNNNNN: Number of the scene (0...63)</p> <p>1-64 in the parameter setup corresponds to the scene number 0-63 sent by the communication object —Number of scene. For example, scene 1 in the parameter setup has the same output result as scene 0 in the communication object —Number of scene.</p> |                 |         |           |       |

Table 6.4 communication object “Scene”

## 6.5. Communication object “HVAC”

| Number | Name | Object Function            | Description | Group Ad... | Length | C | R | W | T | U | Data Type                         | Priority |
|--------|------|----------------------------|-------------|-------------|--------|---|---|---|---|---|-----------------------------------|----------|
| 98     | HVAC | Fan level, cooling         |             |             | 1 Byte | C | R | - | T | - | 8 bit unsigned value DPT_Scaling  | Low      |
| 97     | HVAC | Cooling control value      |             |             | 1 Byte | C | R | - | T | - | 8 bit unsigned value DPT_Scaling  | Low      |
| 96     | HVAC | Frost/heating protectio... |             |             | 1 bit  | C | R | W | T | - | 1 bit DPT_Switch                  | Low      |
| 95     | HVAC | Night operating mode       |             |             | 1 bit  | C | R | W | T | - | 1 bit DPT_Switch                  | Low      |
| 94     | HVAC | Comfort operating mode     |             |             | 1 bit  | C | R | W | T | - | 1 bit DPT_Switch                  | Low      |
| 93     | HVAC | Fan level, heating         |             |             | 1 Byte | C | R | - | T | - | 8 bit unsigned value DPT_Scaling  | Low      |
| 92     | HVAC | Switchover heating/cooling |             |             | 1 bit  | C | R | - | T | - | 1 bit DPT_Switch                  | Low      |
| 91     | HVAC | Heating control value      |             |             | 1 Byte | C | R | - | T | - | 8 bit unsigned value DPT_Scaling  | Low      |
| 90     | HVAC | Setpoint                   |             |             | 2 Byte | C | R | - | - | - | 2 byte float value DPT_Value_Temp | Low      |
| 89     | HVAC | Control on/off             |             |             | 1 bit  | C | - | W | - | - | 1 bit DPT_Switch                  | Low      |
| 94     | HVAC | RTC operating mode         |             |             | 1 Byte | C | R | W | T | - |                                   | Low      |
| 91     | HVAC | Heating control value      |             |             | 1 bit  | C | R | - | T | - | 1 bit DPT_Switch                  | Low      |
| 97     | HVAC | Cooling control value      |             |             | 1 bit  | C | R | - | T | - | 1 bit DPT_Switch                  | Low      |

Fig. 6.5 communication object “HVAC”

| No.   | Object function | Name | Data type | Flags |
|---|-----------------|------|-----------|-------|
| 89  | Control on/off  | HVAC | 1bit      | C,W   |
| <p>The communication object is used to turn on/off HVAC, If a telegram with the value “1” is received at this communication object, the HVAC is switched on, if a telegram with the value “0” is received at this communication object, the HVAC is switched off and all functions of controlling HVAC will not be used.</p> <p>Telegram value:</p> <p>1—on HVAC<br/>0—off HVAC</p> |                 |      |           |       |

|   |                            |      |           |         |
|---|----------------------------|------|-----------|---------|
| 90  | Setpoint                   | HVAC | 2 byte    | C,R,W,T |
| This communication object is used to modify the temperature setpoint or send out the setpoint, read out the setpoint on the bus according to the parameter setting. Temperature range: 10...40°C  |                            |      |           |         |
| 91  | Heating control value      | HVAC | 1bit/byte | C,R,T   |
| The communication object is used to send out the control value for heating function on the bus to control temperature controller on/off.<br>Telegram value (2-point 1bit): on/off<br>Telegram value (2-point 1byte): 0%/100%<br>Telegram value (PI continuous): 0...100%<br>Telegram value (PI PWM 1bit): on/off<br>Telegram value (Fan coil): 0...100% |                            |      |           |         |
| 92  | Switchover heating/cooling | HVAC | 1bit      | C,R,T   |
| The communication object will be visible with "heating and cooling" in the parameter "control function", which is used to send out a telegram to switch between the heating function and the cooling function.<br>Telegram value:<br>1—heating function<br>0—cooling function   |                            |      |           |         |
| 93/98   | Fan level, heating/cooling | HVAC | 1byte     | C,R,T   |
| The communication object can only be used with "fan coil" in the parameter "control type heating/cooling", which is used to send out a telegram with control fan speed, the telegram value is set via parameter.<br>Telegram value: 0...100% (0...255)  |                            |      |           |         |
| 94  | Comfort operating mode     | HVAC | 1bit      | C,R,W,T |
| The communication object will be visible with "1bit" in the parameter "object for operating mode change", if a telegram "1" is sent out at this communication object, the operating mode is switched to the comfort mode for the temperature controller.<br>Telegram value:<br>1—the comfort mode<br>0—the comfort mode off                             |                            |      |           |         |
| 94  | RTC operating mode         | HVAC | 1byte     | C,R,W,T |
| The communication object will be visible with "1byte" in the parameter "object for operating mode change", which is used to send out different telegram values, different values mean different operating mode:<br>1—comfort mode<br>2—standby mode<br>3—night mode<br>4—frost/heating protection mode  |                            |      |           |         |
| 95  | Night operating mode       | HVAC | 1bit      | C,R,W,T |
| The communication object will be visible with "1bit" in the parameter "object for operating mode change"; if a telegram "1" is sent out at this communication object, the operating mode is switched to the night mode for the temperature controller.<br>Telegram value:<br>1—the night mode<br>0—the night mode off                                   |                            |      |           |         |

|  |                               |      |           |         |
|--|-------------------------------|------|-----------|---------|
| 96   | Frost/heating protection mode | HVAC | 1bit      | C,R,W,T |
| <p>The communication object will be visible with “1bit” in the parameter “object for operating mode change”. If a telegram “1” is sent out at this communication object, the operating mode is switched to the frost/heating protection mode for the temperature controller.</p> <p>Telegram value:</p> <p>1—the frost/heating protection mode</p> <p>0—the frost/heating protection mode off</p> <p>If using “1bit” in the parameter “object for operating mode change”, and the telegrams values of the objects for comfort, night and frost/heating protection modes are “0”, the current mode is switched to the standby mode.</p> |                               |      |           |         |
| 97   | Cooling control value         | HVAC | 1bit/byte | C,R,T   |
| <p>The communication object is used to send out the control value for cooling function on the bus to control temperature controller on/off.</p> <p>Telegram value (2-point 1bit): on/off</p> <p>Telegram value (2-point 1byte): 0%/100%</p> <p>Telegram value (PI continuous): 0...100%</p> <p>Telegram value (PI PWM 1bit): on/off</p> <p>Telegram value (Fan coil): 0...100%</p>   |                               |      |           |         |

Table 6.5 communication object “HVAC”

## 6.6. Communication object “Customize”

| Number | Name               | Object Function | Description | Group Ad... | Length | C | R | W | T | U | Data Type        | Priority |
|--------|--------------------|-----------------|-------------|-------------|--------|---|---|---|---|---|------------------|----------|
| 101    | Customize, group A | Value 3         |             |             | 1 bit  | C | - | - | T | - | 1 bit DPT_Switch | Low      |
| 100    | Customize, group A | Value 2         |             |             | 1 bit  | C | - | - | T | - | 1 bit DPT_Switch | Low      |
| 99     | Customize, group A | Value 1         |             |             | 1 bit  | C | - | - | T | - | 1 bit DPT_Switch | Low      |

Fig. 6.6 communication object “Audio”

| No.   | Object function   | Name                         | Data type        | Flags |
|---|-------------------|------------------------------|------------------|-------|
| 99~152  | Value Y (Y=1,2,3) | Customize, group X (X=A...R) | 1bit/1byte/2byte | C,T   |
| <p>The communication object is used to send out a telegram with a predefined value, the predefined value and data type of object can be freely set in the parameters.</p> |                   |                              |                  |       |

Table 6.6 communication object “Audio”

## 6.7. Communication object “Audio”

| Number | Name  | Object Function | Description | Group Addresses | Length  | C | R | W | T | U | Data Type                        | Priority |
|--------|-------|-----------------|-------------|-----------------|---------|---|---|---|---|---|----------------------------------|----------|
| 185    | Audio | Song name       |             |                 | 14 Byte | C | - | W | - | - | Character string                 | Low      |
| 184    | Audio | Sound effect    |             |                 | 1 Byte  | C | - | W | T | - | 8 bit unsigned value DPT_Scaling | Low      |
| 183    | Audio | Shuffle mode    |             |                 | 1 bit   | C | R | W | T | - | 1 bit DPT_Enable                 | Low      |
| 182    | Audio | Repeat mode     |             |                 | 1 bit   | C | R | W | T | - | 1 bit DPT_Enable                 | Low      |
| 181    | Audio | Sleep mode      |             |                 | 1 bit   | C | R | W | T | - | 1 bit DPT_Enable                 | Low      |
| 180    | Audio | Pre/next zone   |             |                 | 1 bit   | C | - | - | T | - |                                  | Low      |
| 159    | Audio | Pre/next song   |             |                 | 1 bit   | C | - | - | T | - |                                  | Low      |
| 158    | Audio | Status volume   |             |                 | 1 Byte  | C | - | W | - | - | 8 bit unsigned value DPT_Scaling | Low      |
| 157    | Audio | Pause           |             |                 | 1 bit   | C | - | W | T | - | 1 bit DPT_Enable                 | Low      |
| 156    | Audio | Volume control  |             |                 | 1 Byte  | C | - | - | T | - | 8 bit unsigned value DPT_Scaling | Low      |
| 155    | Audio | Mute on/off     |             |                 | 1 bit   | C | - | W | T | - | 1 bit DPT_Enable                 | Low      |
| 154    | Audio | Play/stop       |             |                 | 1 bit   | C | - | W | T | - | 1 bit DPT_Start                  | Low      |
| 153    | Audio | On/off          |             |                 | 1 bit   | C | - | W | T | - | 1 bit DPT_Switch                 | Low      |

Fig. 6.7 communication object “Audio”

| No. | Object function | Name | Data type | Flags |
|-----|-----------------|------|-----------|-------|
|-----|-----------------|------|-----------|-------|

|   |                |       |       |         |
|---|----------------|-------|-------|---------|
| 153   | On/off         | Audio | 1bit  | C,W,T   |
| <p>The communication object is used to send out a telegram with on/off, to turn on or off a music module.</p> <p>Telegram value:</p> <p>1—on</p> <p>0—off</p> <p>If the object has not sent or received a telegram “on”, other operations cannot be used and cannot receive telegrams from the bus. After programming application, the audio control is off by default.</p> |                |       |       |         |
| 154   | Play/stop      | Audio | 1bit  | C,W,T   |
| <p>The communication object is used to send out a telegram with start or stop playing.</p> <p>Telegram value:</p> <p>1—play/start</p> <p>0—stop</p>   |                |       |       |         |
| 155   | Mute on/off    | Audio | 1bit  | C,W,T   |
| <p>The communication object is used to send out a telegram with entering or exiting mute mode.</p> <p>Telegram value:</p> <p>1—enable mute</p> <p>0—disable mute</p>  |                |       |       |         |
| 156   | Volume control | Audio | 1byte | C,T     |
| <p>The communication object is used to set the volume to an absolute value. Range from 0 to 100%</p>  |                |       |       |         |
| 157   | pause          | Audio | 1bit  | C,W,T   |
| <p>The communication object is used to send out a telegram with temporarily halt playing.</p> <p>Telegram value:</p> <p>1—pause</p> <p>0—resume</p> <p>When the operating button “play/stop” is “stop” status, the button “pause” is disabled.</p>  |                |       |       |         |
| 158   | Status volume  | Audio | 1byte | C,W     |
| <p>The communication object is used to receive status response with the volume from a music module on the bus and display it in the TFT system.</p>   |                |       |       |         |
| 159   | Pre/next song  | Audio | 1bit  | C,T     |
| <p>The communication object is used to send out a telegram with songs change, to change to backward song or forward song</p> <p>Telegram value:</p> <p>1—forward song</p> <p>0—backward song</p>  |                |       |       |         |
| 160   | Pre/next zone  | Audio | 1bit  | C,T     |
| <p>The communication object is used to send out a telegram with playlist of music module change.</p> <p>Telegram value:</p> <p>1—forward playlist</p> <p>0—backward playlist</p>  |                |       |       |         |
| 161   | Sleep mode     | Audio | 1bit  | C,R,W,T |
| <p>This communication object is used to activate and deactivate the sleep mode.</p> <p>Telegram value:</p> <p>1—enable sleep mode</p> <p>0—disable sleep mode</p>   |                |       |       |         |

|  |              |       |        |         |
|--|--------------|-------|--------|---------|
| 162  | Repeat mode  | Audio | 1bit   | C,R,W,T |
| <p>This communication object is used to activate and deactivate the repeat mode.</p> <p>Telegram value:</p> <p>1—enable repeat mode</p> <p>0—disable repeat mode</p>   |              |       |        |         |
| 163  | Shuffle mode | Audio | 1bit   | C,R,W,T |
| <p>This communication object is used to activate and deactivate the shuffle mode.</p> <p>Telegram value:</p> <p>1—enable shuffle mode</p> <p>0—disable shuffle mode</p> <p>Note: the objects “repeat mode” and “shuffle mode” are sent to the bus together, if they are disabled, then the player will play in sequence.</p> |              |       |        |         |
| 164  | Sound effect | Audio | 1byte  | C,W,T   |
| <p>The communication object used to adjust the sound effect of music.</p> <p>Telegram value:</p> <p>0—Hip-hop</p> <p>1—Knight</p> <p>2—Dance</p> <p>3—Popular</p> <p>4—Classical</p>   |              |       |        |         |
| 165  | Song name    | Audio | 14byte | C,W     |
| <p>The communication object is used to receive the song name from a music module sending on the bus and display it in the TFT system.</p>  |              |       |        |         |

Table 6.7 communication object “Audio”

## 6.8. Communication object “Air condition”

| Number | Name          | Object Function               | Descrrip... | Group Addresses | Length | C | R | W | T | U | Data Type                          | Priority |
|--------|---------------|-------------------------------|-------------|-----------------|--------|---|---|---|---|---|------------------------------------|----------|
| 189    | Air Condition | Setpoint for cooling          | 30/31       |                 | 1 bit  | C | - | - | T | - | 1 bit DPT_Switch                   | Low      |
| 188    | Air Condition | Setpoint for cooling          | 28/29       |                 | 1 bit  | C | - | - | T | - | 1 bit DPT_Switch                   | Low      |
| 187    | Air Condition | Setpoint for cooling          | 26/27       |                 | 1 bit  | C | - | - | T | - | 1 bit DPT_Switch                   | Low      |
| 186    | Air Condition | Setpoint for cooling          | 24/25       |                 | 1 bit  | C | - | - | T | - | 1 bit DPT_Switch                   | Low      |
| 185    | Air Condition | Setpoint for cooling          | 22/23       |                 | 1 bit  | C | - | - | T | - | 1 bit DPT_Switch                   | Low      |
| 184    | Air Condition | Setpoint for cooling          | 20/21       |                 | 1 bit  | C | - | - | T | - | 1 bit DPT_Switch                   | Low      |
| 183    | Air Condition | Setpoint for cooling          | 18/19       |                 | 1 bit  | C | - | - | T | - | 1 bit DPT_Switch                   | Low      |
| 182    | Air Condition | Setpoint for cooling          | 16/17       |                 | 1 bit  | C | - | - | T | - | 1 bit DPT_Switch                   | Low      |
| 181    | Air Condition | Setpoint for heating          | 30/31       |                 | 1 bit  | C | - | - | T | - | 1 bit DPT_Switch                   | Low      |
| 180    | Air Condition | Setpoint for heating          | 28/29       |                 | 1 bit  | C | - | - | T | - | 1 bit DPT_Switch                   | Low      |
| 179    | Air Condition | Setpoint for heating          | 26/27       |                 | 1 bit  | C | - | - | T | - | 1 bit DPT_Switch                   | Low      |
| 178    | Air Condition | Setpoint for heating          | 24/25       |                 | 1 bit  | C | - | - | T | - | 1 bit DPT_Switch                   | Low      |
| 177    | Air Condition | Setpoint for heating          | 22/23       |                 | 1 bit  | C | - | - | T | - | 1 bit DPT_Switch                   | Low      |
| 176    | Air Condition | Setpoint for heating          | 20/21       |                 | 1 bit  | C | - | - | T | - | 1 bit DPT_Switch                   | Low      |
| 175    | Air Condition | Setpoint for heating          | 18/19       |                 | 1 bit  | C | - | - | T | - | 1 bit DPT_Switch                   | Low      |
| 174    | Air Condition | Setpoint for heating          | 16/17       |                 | 1 bit  | C | - | - | T | - | 1 bit DPT_Switch                   | Low      |
| 173    | Air Condition | Wind auto/stop                |             |                 | 1 bit  | C | - | - | T | - | 1 bit DPT_Switch                   | Low      |
| 172    | Air Condition | Wind LK/UD                    |             |                 | 1 bit  | C | - | - | T | - | 1 bit DPT_Switch                   | Low      |
| 171    | Air Condition | Switch to peed low            |             |                 | 1 bit  | C | - | - | T | - | 1 bit DPT_Switch                   | Low      |
| 170    | Air Condition | Switch over high/medium speed |             |                 | 1 bit  | C | - | - | T | - | 1 bit DPT_Switch                   | Low      |
| 169    | Air Condition | Mode auto/dry                 |             |                 | 1 bit  | C | - | - | T | - | 1 bit DPT_Switch                   | Low      |
| 168    | Air Condition | Mode heating/cooling          |             |                 | 1 bit  | C | - | - | T | - | 1 bit DPT_Switch                   | Low      |
| 167    | Air Condition | Air Condition on/off          |             |                 | 1 bit  | C | - | - | T | - | 1 bit DPT_Switch                   | Low      |
| 166    | Air Condition | Setpoint                      |             |                 | 2 Byte | C | R | W | T | - | 2 byte float value DPT_Value_Temp  | Low      |
| 167    | Air Condition | IR command number             |             |                 | 1 Byte | C | - | - | T | - | 8 bit unsigned value DPT_Value_... | Low      |

Fig. 6.8 communication object “Air condition”



| No.  | Object function              | Name          | Data type | Flags   |
|--|------------------------------|---------------|-----------|---------|
| 166  | Setpoint                     | Air condition | 2byte     | C,R,W,T |
| <p>This communication object is used to read out the setpoint, modify the temperature setpoint or send out the setpoint on the bus according to the parameter setting. In the default parameter settings, the setpoint can only be read out.</p>   |                              |               |           |         |
| 167  | Air Condition on/off         | Air condition | 1bit      | C,T     |
| <p>The communication object is visible with “1bit” in the parameter “object type for control air condition”, which is used to send out a telegram with air-condition on/off.</p> <p>Telegram value:</p> <p style="padding-left: 40px;">1—air condition on<br/>0—air condition off</p> <p>When the object sends a telegram “off”, other button can be operated, but no telegrams are sent. To facilitate control air condition, the TFT will record temperature, speed and swing icons state for each mode, so when switch the modes, it may appear that the display setpoint is inconsistent with the actual setpoint.</p> |                              |               |           |         |
| 167  | IR command number            | Air condition | 1byte     | C,T     |
| <p>The communication object is visible with “1byte” in the parameter “object type for control air condition”, which is used to send out a telegram with control command of air-condition, the telegram values corresponds to different commands are set via the parameters.</p>  |                              |               |           |         |
| 168  | Mode heating/cooling         | Air condition | 1bit      | C,T     |
| <p>The communication object will be visible with “1bit” in the parameter “object type for control air condition”, which is used to send out a telegram with switching to the heating mode or the cooling mode.</p> <p>Telegram value:</p> <p style="padding-left: 40px;">1—heating mode<br/>0—cooling mode</p>   |                              |               |           |         |
| 169  | Mode auto/dry                | Air condition | 1bit      | C,T     |
| <p>The communication object will be visible with “1bit” in the parameter “object type for control air condition”, which is used to send out a telegram with switching to the auto mode or the dry mode.</p> <p>Telegram value:</p> <p style="padding-left: 40px;">1—auto mode<br/>0—dry mode</p>   |                              |               |           |         |
| 170  | Switchover high/medium speed | Air condition | 1bit      | C,T     |
| <p>The communication object will be visible with “1bit” in the parameter “object type for control air condition”, which is used to send out a telegram with high fan speed or medium speed.</p> <p>Telegram value:</p> <p style="padding-left: 40px;">1—high fan speed<br/>0—medium fan speed</p>  |                              |               |           |         |
| 171  | Switch to low speed          | Air condition | 1bit      | C,T     |
| <p>The communication object will be visible with “1bit” in the parameter “object type for control air condition”, which is used to send out a telegram with low fan speed.</p> <p>Telegram value:</p> <p style="padding-left: 40px;">1—low fan speed</p>   |                              |               |           |         |

|  |                          |               |      |     |
|--|--------------------------|---------------|------|-----|
| 172  | Wind LR/UD               | Air condition | 1bit | C,T |
| <p>The communication object will be visible with “1bit” in the parameter “object type for control air condition”, which is used to send out a telegram with wind LR/UD.</p> <p>Telegram value:</p> <p>1—wind left/right</p> <p>0—wind up/down</p>                                |                          |               |      |     |
| 173  | Wind auto/stop           | Air condition | 1bit | C,T |
| <p>The communication object will be visible with “1bit” in the parameter “object type for control air condition”, which is used to send out a telegram with wind auto/stop.</p> <p>Telegram value:</p> <p>1—wind auto</p> <p>0—wind stop</p>                                     |                          |               |      |     |
| 174~181  | Setpoint for heating X/Y | Air condition | 1bit | C,T |
| <p>The communication object will be visible with “1bit” in the parameter “object type for control air condition”, which is used to send out a telegram with the temperature setpoint X/Y in the heating mode.</p> <p>Telegram value:</p> <p>1—setpoint X</p> <p>0—setpoint Y</p> |                          |               |      |     |
| 182~189  | Setpoint for cooling X/Y | Air condition | 1bit | C,T |
| <p>The communication object will be visible with “1bit” in the parameter “object type for control air condition”, which is used to send out a telegram with the temperature setpoint X/Y in the cooling mode.</p> <p>Telegram value:</p> <p>1—setpoint X</p> <p>0—setpoint Y</p> |                          |               |      |     |

Table 6.8 communication object table “Air condition”

## 6.9. Communication object “Security”

| Number | Name       | Object Function  | Descrip... | Group Addresses | Length | C | R | W | T | U | Data Type        | Priority |
|--------|------------|------------------|------------|-----------------|--------|---|---|---|---|---|------------------|----------|
| 190    | Security 1 | Disarming/arming |            |                 | 1 bit  | C | - | - | T | - | 1 bit DPT_Enable | Low      |

Fig. 6.9 communication object “Security”

| No.   | Object function  | Name       | Data type | Flags |
|---|------------------|------------|-----------|-------|
| 190   | Disarming/arming | Security X | 1bit      | C,T   |
| <p>The communication object is used to send out a telegram with disarming or arming security function.</p> <p>Telegram value:</p> <p>1—arming, active security system</p> <p>0—disarming, inactive security system</p> <p>or</p> <p>0—arming, active security system</p> <p>1—disarming, inactive security system</p> <p>According to the working mode of security function to select one of two cases.</p> |                  |            |           |       |

Table 6.9 communication object table “Security”

## 6.10. Communication object “RGB LED dimming”

The following objects are used to dim for RGB LED. Three objects among them used to send out brightness value telegrams for R (red), G (green) and B (blue) three-channels, another three objects are used to receive brightness status of the three-channel response. Therefore, the TFT can be used for dimming RGB LED, and we can see brightness status of RGB LED in the TFT system.

| Number | Name            | Object Function | Descrip... | Group Addresses | Length | C | R | W | T | U | Data Type                        | Priority |
|--------|-----------------|-----------------|------------|-----------------|--------|---|---|---|---|---|----------------------------------|----------|
| 201    | RGB LED dimming | Status, B       |            |                 | 1 Byte | C | - | W | - | - | 8 bit unsigned value DPT_Scaling | Low      |
| 200    | RGB LED dimming | Status, G       |            |                 | 1 Byte | C | - | W | - | - | 8 bit unsigned value DPT_Scaling | Low      |
| 199    | RGB LED dimming | Status, R       |            |                 | 1 Byte | C | - | W | - | - | 8 bit unsigned value DPT_Scaling | Low      |
| 198    | RGB LED dimming | 1byte dimmer, B |            |                 | 1 Byte | C | - | - | T | - | 8 bit unsigned value DPT_Scaling | Low      |
| 197    | RGB LED dimming | 1byte dimmer, G |            |                 | 1 Byte | C | - | - | T | - | 8 bit unsigned value DPT_Scaling | Low      |
| 196    | RGB LED dimming | 1byte dimmer, R |            |                 | 1 Byte | C | - | - | T | - | 8 bit unsigned value DPT_Scaling | Low      |

Fig. 6.10 communication object “RGB LED dimming”

| No.  | Object function  | Name            | Data type | Flags |
|--|------------------|-----------------|-----------|-------|
| 196  | 1 byte dimmer, R | RGB LED dimming | 1byte     | C,T   |
| The communication object is used to send out the brightness value of R (red).            |                  |                 |           |       |
| 197  | 1 byte dimmer, G | RGB LED dimming | 1byte     | C,T   |
| The communication object is used to send out the brightness value of G (green).          |                  |                 |           |       |
| 198  | 1 byte dimmer, B | RGB LED dimming | 1byte     | C,T   |
| The communication object is used to send out the brightness value of B (blue).           |                  |                 |           |       |
| 199  | Status, R        | RGB LED dimming | 1byte     | C,W   |
| The communication object is used to receive the brightness status of R (red) response.   |                  |                 |           |       |
| 200  | Status, G        | RGB LED dimming | 1byte     | C,W   |
| The communication object is used to receive the brightness status of G (green) response. |                  |                 |           |       |
| 201  | Status, B        | RGB LED dimming | 1byte     | C,W   |
| The communication object is used to receive the brightness status of B (blue) response.  |                  |                 |           |       |

Table 6.10 communication object table “RGB LED dimming”

## 6.11. Communication object “Logic”

The communication object type can be 1bit or 1byte for logic function via the parameter setting. Regardless of which type, if the object value is 0, the results is false, if the object value is greater than 0, the result is true.

| Number | Name    | Object Function | Descrip... | Group Addresses | Length | C | R | W | T | U | Data Type        | Priority |
|--------|---------|-----------------|------------|-----------------|--------|---|---|---|---|---|------------------|----------|
| 204    | Logic 1 | Output          |            |                 | 1 bit  | C | - | - | T | - | 1 bit DPT_Switch | Low      |
| 203    | Logic 1 | Input 2         |            |                 | 1 bit  | C | - | W | - | - | 1 bit DPT_Switch | Low      |
| 202    | Logic 1 | Input 1         |            |                 | 1 bit  | C | - | W | - | - | 1 bit DPT_Switch | Low      |

Fig. 6.11 communication object “Logic”

| No.  | Object function | Name    | Data type  | Flags |
|--|-----------------|---------|------------|-------|
| 202  | Input 1         | Logic X | 1bit/1byte | C,W   |
| The communication object is used to receive a telegram with the logic value of input1.         |                 |         |            |       |
| 203  | Input 2         | Logic X | 1bit/1byte | C,W   |
| The communication object is used to receive a telegram with the logic value of input2.         |                 |         |            |       |
| 204  | Output          | Logic X | 1bit/1byte | C,T   |
| The communication object is used to send out the logic operating result for input1 and input2. |                 |         |            |       |

Table 6.11 communication object table “Logic”

## 7. Appendix

### TFT operation interfaces and icons instruction

#### 7.1 The main interface

There are two main page styles:



Cover flow

To enter the setting interface



Squares

There can display time, date, indoor and outdoor temperatures and function blocks in the main interface.

There is a button in the top right side of main interface to enter the setting interface.

In the case of squares, don't display temperatures.

To back to the main interface from the function interface via drop-down page. If the function interface has multi-pages, carry out pages turning by sideslip.

## 7.2 Password interface

The password interface is shown as the picture at right.

It needs to input the password to entry the setting interface. The waiting time of input password is 7s, once the time has passed, turn the password interface off.

After block operation, it also need to input the password to deblocking, its waiting time is relate to screensaver time, if the screensaver time is 90s, then when the time has passed, turn the password interface off.

Disarm also need to enter the password.

When the “cancel” button is gray in the password interface, it means that the cancel operation is not available.

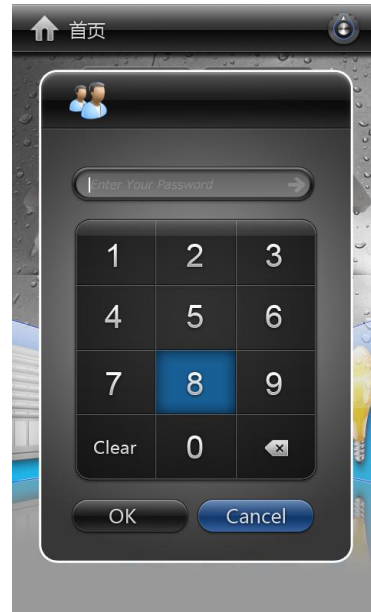

## 7.3 Settings interface

The settings interface is shown as the picture at right. To enter modify each setting by clicking symbols at right. Settings as follow:

**Language:** There are 16 system languages, but now only support Chinese and English;

**Date:** modify date;

**Main page style:** Cover flow and squares, in the case of squares, don't display temperature;

**Time:** Modify time, now the setting “use 24-Hours Format” is not available;

**Password:** Modify password, when set a new password, if the new password is empty, mean that no password;

**Screen saver:** Modify screen saver setting, e.g. whether enable screen saver, two screen saver types “Album” and “Clock” can be selected, and the time that begin to carry out screen saver;

**Warning tone:** Switch on or off the warning tone, if on, it will be sound when operating.

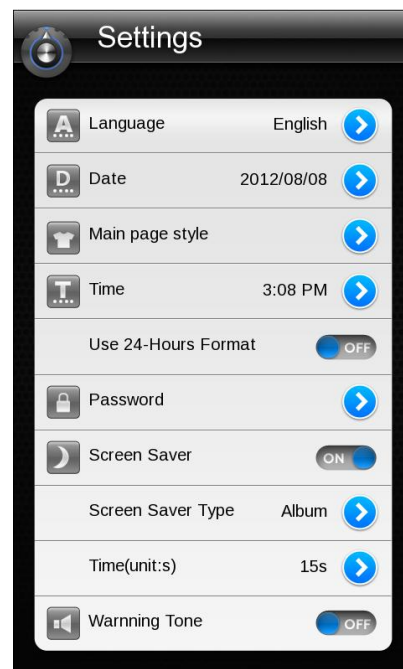

## 7.4 Lighting control interface

### 1. Icons instruction

The follow is the icon number 0...7 corresponding pictures, color icon – light on, grey icon – light off, the images with arrow mean that the lights can be dimmed.



| 0             | 1         | 2         | 3                | 4                          | 5                      | 6                      | 7                             |
|---------------|-----------|-----------|------------------|----------------------------|------------------------|------------------------|-------------------------------|
| General light | Desk lamp | Droplight | Fluorescent lamp | General light with dimming | Desk lamp with dimming | Droplight with dimming | Fluorescent lamp with dimming |

### 2. Operation interface

The light control interface is shown as the picture at right.

Send a switch telegram via a short operation.

Entry dimming operation via a long operation (depend on parameter setting).

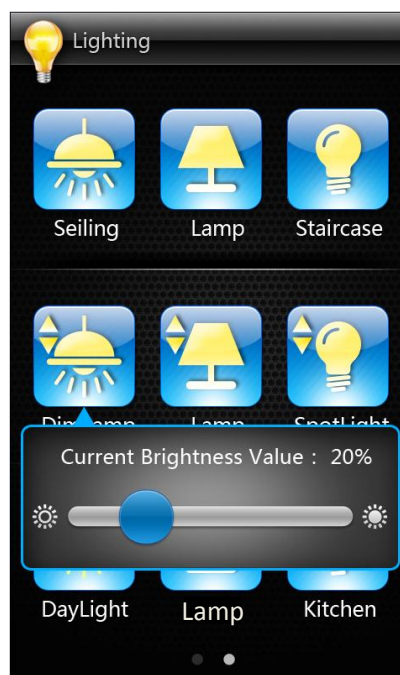

## 7.5 Shutter / blind control interface

### 1. Icons instruction

A color icon and a grey icon form an operating action.



| 0                      | 1         | 2                          | 3          | 4    | 5           |
|------------------------|-----------|----------------------------|------------|------|-------------|
| Move up/<br>lamella up | Stop move | Move down/<br>lamella down | Open blind | Stop | Close blind |

### 2. Operation interface

The shutter/blind control interface is shown as the picture at right.

In the case of shutter, send a blind up telegram via a long operation of left button and send a blind down telegram via a long operation of right button, send a lamella up telegram via a short operation of left button and send a lamella down telegram via a short operation of right button.





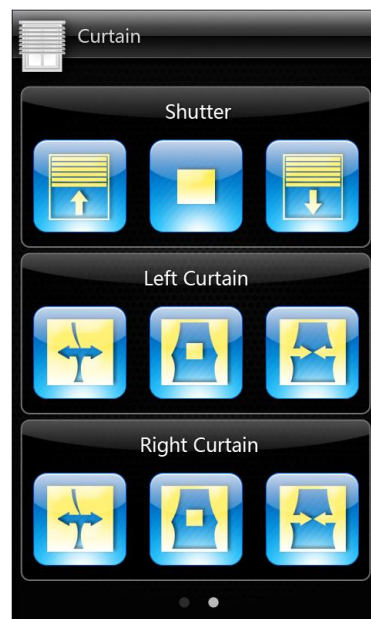















In the case of blind, send a blind open telegram via left button and send a blind close telegram via right button.

The middle button is used to stop blind/shutter travel.



## 7.6 Scene control interface

### 1. Icons instruction

|   |   |   |   |   |  |   |   |
|---|---|---|---|---|--|---|---|
|  |  |  |  |  |  |  |  |
| 0   | 1   | 2   | 3   | 4   | 5  | 6   | 7   |
| Relaxation  | Movie   | TV  | Meeting   | Read  | Relaxation   | See visitor   | Public facilities light off   |
|  |  |  |  |  |  |  |  |
| 8   | 9   | 10  | 11  | 12  | 13   | 14  | 15  |
| At home   | Cleaning  | Game  | All light off   | All light on  | Dinner   | Movie   | TV  |
|  |  |  |  |  |  |  |  |
| 16  | 17  | 18  | 19  | 20  | 21   | 22  | 23  |
| Sleep   | Leave home  | Dance   | Sports  | Reception   | Read   | Music   | General   |

### 2. Operation interface

The scene control interface is shown as the picture at right.

Recall scene via a short operation.

Storage scene via a long operation (depend on parameter setting).





## 7.7 HVAC control interface

### 1. Icons instruction

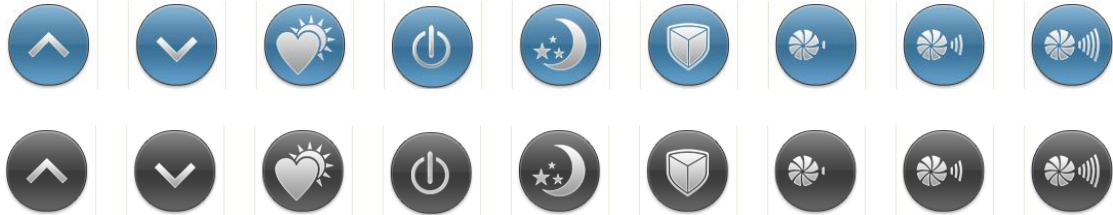

| 0           | 1             | 2            | 3            | 4          | 5                             | 6              | 7                 | 8               |
|-------------|---------------|--------------|--------------|------------|-------------------------------|----------------|-------------------|-----------------|
| Setpoint up | Setpoint down | Comfort mode | Standby mode | Night mode | Frost/heating protection mode | Low wind speed | Middle wind speed | High wind speed |

| 9       | 10      | 11                   |
|---------|---------|----------------------|
| Cooling | Heating | Setpoint display box |

### 2. Operation interface

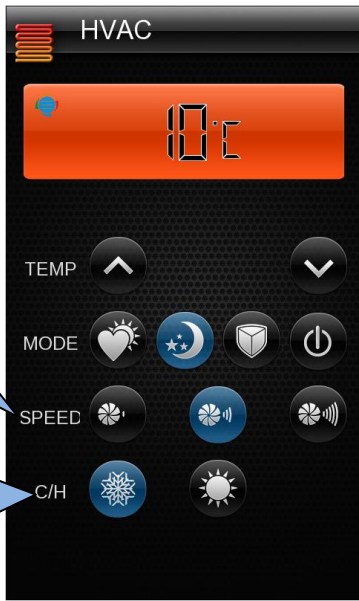

Visible in the control type "fan coil"

Visible in the control function "heating and cooling"

The HVAC control interface is shown as the picture at left. In the case of different control functions and control types, the operation interface will be different.

**Temp:** Adjust the temperature setpoint of the current mode;

**Mode:** Select different operation mode;

**Speed:** There are high, middle and low wind speeds to select;



































**C/H:** Select the control function, cooling or heating.

## 7.8 Sending of customize value interface

Icons of the function are the same as the icons of scene, so here no longer description them.

## 7.9 Audio control interface

### 1. Icons instruction

|   |   |   |   |   |   |  |   |   |
|---|---|---|---|---|---|--|---|---|
|  |  |  |  |  |  |  |  |  |
|  |  |  |  |  |  |  |  |  |
| 0   | 1   | 2   | 3   | 4   | 5   | 6  | 7   | 8   |
| Backward playlist   | Backward song   | Forward song  | Forward playlist  | Mute  | Shuffle mode  | Repeat mode  | Sleep/timing  | switch  |
|  |  |  |  |  |  |  |  |  |
|  |  |  |  |  |  |  |   |   |
| 9   | 10  | 11  | 12  | 13  | 14  | 15   | 16  | 17  |
| Hip Hop   | knight  | Dance   | Popular   | Classical   | Start/stop  | Pause  | Volume decrease   | Volume increase   |

  

|                       |
|-----------------------|
| 18                    |
| Song name display box |

### 2. Operation interface





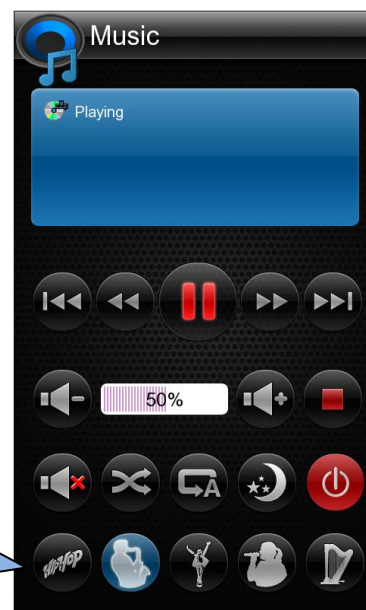

























The Audio control interface is shown as the picture at right. If the Audio is switched off, the operation interface will back to initial state “power off” and other operations are not available, the current state is “playing” in the fig.

Sound effect: hip-hop、knight、dance、popular、classical



## 7.10 Air conditioning control interface

### 1. Icons instruction

|  |  |  |  |  |   |  |   |   |
|--|--|--|--|--|---|--|---|---|
|   |   |   |   |   |    |  |  |  |
|   |   |   |   |   |    |  |  |  |
| 0  | 1  | 2  | 3  | 4  | 5   | 6  | 7   | 8   |
| Auto mode  | Heating mode   | Cooling mode   | Dry mode   | Setpoint up  | Setpoint down   | Low wind speed   | Middle wind speed   | High wind speed   |
|   |   |   |   |   |   |  |   |   |
|  |  |  |  |  |  |  |   |   |
| 9  | 10   | 11   | 12   | 13   | 14  |  |   |   |
| Wind up/down   | Wind auto  | Wind left/right  | Wind stop  | Air condition on/off   | Setpoint display box, on/off display  |  |   |   |

### 2. Operation interface

The AC control interface is shown as the picture at right. If the AC is switched off, other operations are not available, i.e. control telegrams will not be sent to the bus.

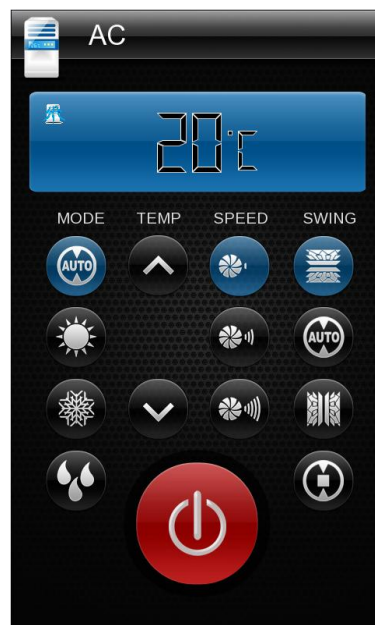

## 7.11 Security setting interface

### 1. Icons instruction

|   |   |   |   |   |   |
|---|---|---|---|---|---|
|  |  |  |  |  |  |
| <b>0</b>  | <b>1</b>  | <b>2</b>  | <b>3</b>  | <b>4</b>  | <b>5</b>  |
| <b>Open arming window</b>   | <b>Close arming window</b>  | <b>Open disarming window</b>  | <b>Close disarming window</b>   | <b>Armed</b>  | <b>Disarmed</b>   |

### 2. Operation interface

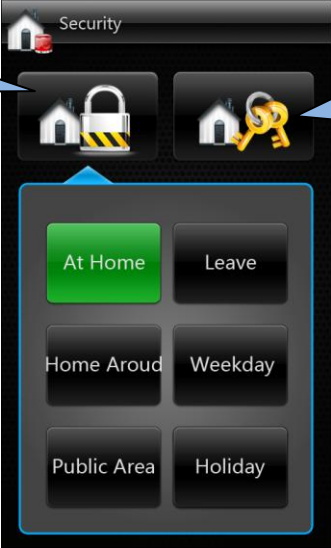

Open arming interface

Open disarming interface and input password

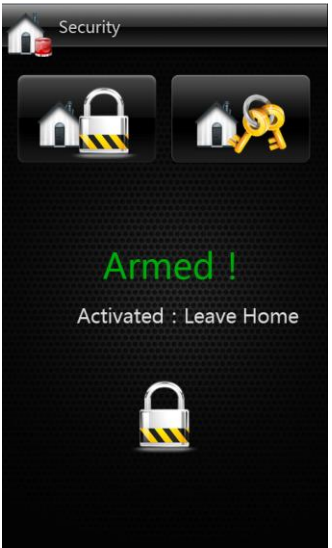

Arming/disarming interface  
Already arming, the icon shows green

The current arming

## 7.12 RGB LED dimming interface

### Operation interface

The RGB LED operation interface is shown as the picture at right.

The current color is probably effect of R, G and B three color mixtures.

If the three-color LED lighting effect you need is similar with the colors of squares at the bottom of the interface, you can click the corresponding color squares to recall it directly.

If you want to custom lighting effect, you can adjust R, G and B slider.

